

HITACHI

NP6C/NP6C-2 Chassis Models CRP-143, CTP-203 CTP-213, CWP-132

CAUTION:

Before servicing this chassis, it is important that the service technician read the "Safety Precaution" and "Product Safety Notices" in this Service Manual.

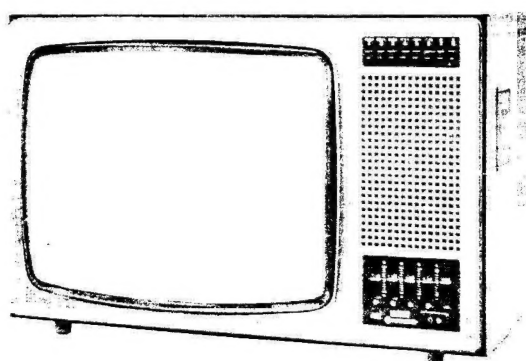

CONTENTS

TECHNICAL SEPCIFICATIONS	1
SAFETY PRECAUTIONS	2
CONFIGURATION OF CHASSIS	2
TECHNICAL PRECAUTIONS	3
CONTROL	6
TECHNICAL FEATURES	6
BLOCK DIAGRAM	8
VOLTAGE SUPPLY DIAGRAM	9
CONNECTION FOR ALIGNMENT	10
PRIMARY ALIGNMENT	11
PRINTED WIRING BOARD	19
CIRCUIT DIAGRAM	25
REPLACEMENT PARTS LIST	26

TECHNICAL SPECIFICATIONS

TV standard	625-line single standard
Channel coverage	UHF channels 21-68
Aerial input impedance	75-ohm unbalanced
Intermediate frequencies	
I.F. luminance	39.50 MHz
I.F. Sound	33.50 MHz
I.F. Chrominance	35.07 MHz
F.M. Sound	6.00 MHz
Colour subcarrier	4.43 MHz
Convergence	Self-convergence
Focusing	Electro-static
Mains voltage	240V ~ 50Hz
Fuses	
Mains input	2A/T x 1
Regulate line	800mA/T x 1
	630mA/T x 1

Picture tube20", 510HWB22
Programme Selectors	Push button selector
IC's	3
Transistors	46
Diodes	57
Speaker	10 x 15cm
Sound output	3W at 400Hz
Power consumption	75W
Dimensions	
W	65.4cm
H	43.0cm
D	45.6cm
Weight	appr. 25kg

SOLID STATE COLOUR TELEVISION

March 1977

SAFETY PRECAUTIONS

WARNING : Since the chassis of this receiver is connected to one side of the Mains Supply during operation, service should not be attempted by anyone unfamiliar with the precautions necessary when working on this type of equipment. The following precautions should be observed.

1. Do not install, remove, or handle the picture tube in any manner unless shatter-proof goggles are worn. People not so equipped should be kept away while picture tubes are handled. Keep picture tube away from the body while handling.
2. When service is required, an isolation transformer should be inserted between power line and the receiver before any service is performed on a "HOT" chassis receiver.
3. When replacing a chassis in the cabinet, always replace all the protective devices are put back in place, such as; barriers, non-metallic knobs, adjustment and compartment cover or shields, isolation resistor-capacitor, etc.
4. When service is required, observe the original lead dress. Extra precaution should be taken to assure correct lead dress in the high voltage circuitry area.
5. Always use the manufacturer's replacement component. Especially critical components as indicated on the circuit diagram should not be replaced by other makes. Furthermore where a short circuit has occurred, replace those components that indicate evidence of overheating.
6. Before returning a serviced receiver to the customer, the service technician must thoroughly test the unit to be certain that it is completely safe to operate without danger of electrical shock, and be sure that no protective device built into the instrument by the manufacturer has become defective, or inadvertently defeated during servicing.

Therefore, the following checks are recommended for the continued protection of the customers and service technicians.

INSULATION

Insulation resistance should not be less than $7M\Omega$ at 500V DC between the mains poles and any accessible metal parts.

Also, No flashover or breakdown should occur during the dielectric strength test, to apply 4KV AC for one minute between the mains poles and any accessible metal parts.

HIGH VOLTAGE

High voltage should always be kept at rated value of the chassis, no higher. Operating at higher voltage may cause a failure of the picture tube or high voltage supply and, also, under certain circumstances could produce X-radiation moderately in excess of design levels. The high voltage must not, under any circumstances, exceed 25KV on the chassis.

X- RADIATION

TUBES: The primary source of X radiation in this receiver is the picture tube. The tube utilized for the above mentioned function in this chassis is specially constructed to limit X radiation emissions.

For continued X radiation protection, the replacement tube must be the same type as the original, HITACHI approved type.

PRODUCT SAFETY NOTICE

Many electrical and mechanical parts in HITACHI television receiver have special safety related characteristics. These characteristics are often not evident from visual inspection nor can the protection afforded by them necessarily be obtained by using replacement components rated for higher voltage, wattage, etc. Replacement parts which have these special safety characteristics are identified in this Service Manual.

Electrical components having such features are identified by marking with a Δ on the schematics and on the parts the parts list in this Service Manual.

The use of a substitute replacement component which does not have the same safety characteristics as the HITACHI recommended replacement one, shown in the parts list in this Service Manual, may create shock, fire, X radiation, or other hazards.

Product Safety is continuously under review and new instructions are issued from time to time. For the latest information, always consult the current HITACHI Service Manual. A subscription to, or additional copies of, HITACHI Service Manual may be obtained at a nominal charge from your HITACHI SALES CORPORATION.

CONFIGURATION OF CHASSIS

NP6C chassis consists of two principle circuit units, i.e. the signal unit and the power supply & deflection unit. The construction of this television receiver is described on a chart as below.

A major part of the units and boards are connected through plug-in system and no solder iron is needed on disassembling.

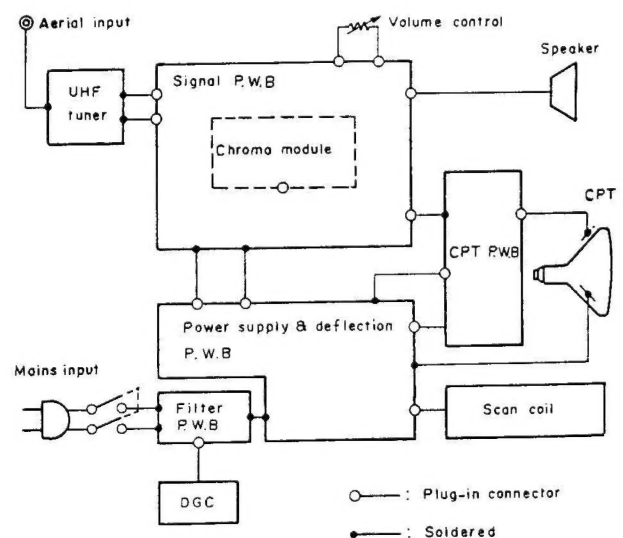

Fig. 1

TECHNICAL PRECAUTIONS

1. Power supply circuit (HT1 stabilizing circuit)

a) Circuit function

Power supply circuit incorporated in NP6C chassis is a switching mode stabilized power supply, and its block diagram is shown in Fig. 2.

Mains input is rectified and this unstabilized DC voltage is switched by the line frequency synchronized switching signal.

The duration of the switched square wave is altered and this switched square wave is rectified, hence stabilized HT1 output is obtained.

When switching on the receiver, the switching signal is derived from the oscillator and after starting on, the shaped pulse from the line output stage is fed to the pulse width modulator.

Output (HT1) is compared with the reference voltage and the amount of error detected, being fed to pulse

width modulator, alter the duty ratio of switching signal and stabilize HT 1.

Two thick film module incorporated are for setting of HT 1 and HV (EHT) limit circuit and no adjustment is necessary.

b) Replacement

If the replacement of any component listed below is necessary, no spare parts should be replaced but those approved and appointed by HITACHI.

Component	Circuit No.
Voltage setting module	CP 901
Error amp. Transistor	TR 907
Resistor	R 928

After the replacement has been carried out, be sure to check and see that HT 1 output is within $110.0 \pm 3V$.

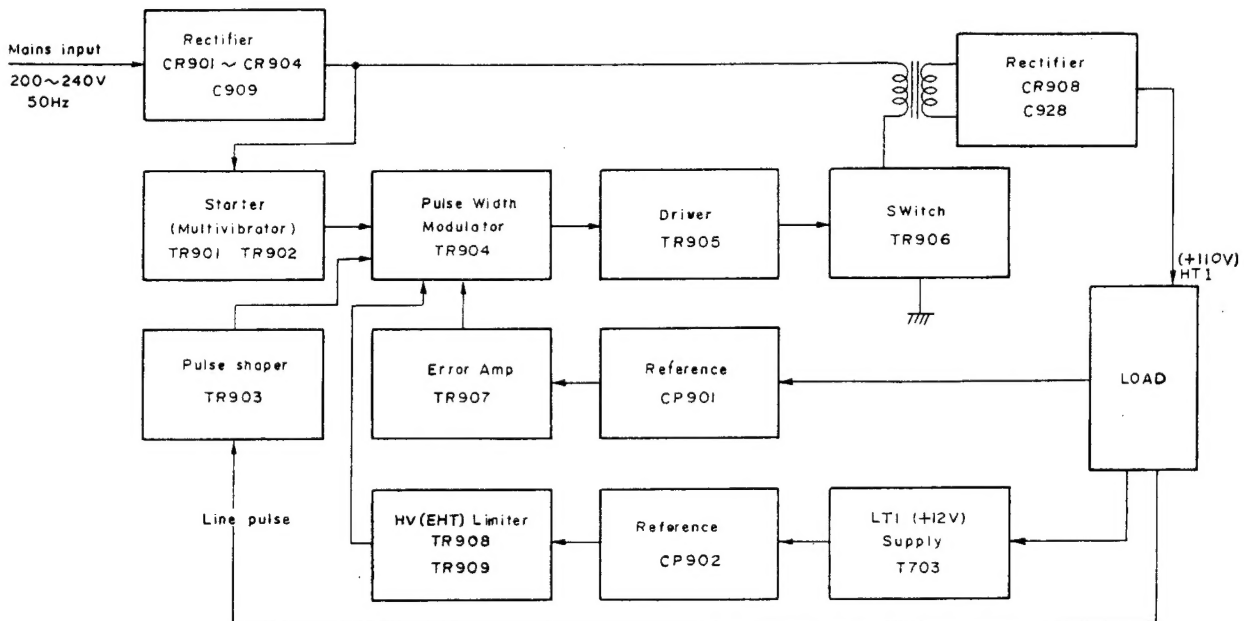

Fig. 2

c) Voltage setting module

The chassis incorporates newly developed thick film voltage setting modules.

These are for HT 1 voltage setting and HV (EHT) limiting. The module includes two functions, voltage divider and reference voltage stage as shown in Fig. 3 (b).

Fig. 3 (a) shows a conventional error detector.

HT 1 output is divided by the resistors R1 and R2, and compared with the reference voltage produced by CR1. The amount of error is amplified and fed back to stabilize the HT 1.

A conventional type has a potentiometer R2, which absorbs the component's tolerances as of resistor R1 etc.,

and alter the dividing ratio, therefore stabilized HT 1 is derived.

Fig. 3 (b) shows a error detector with the voltage setting module incorporated.

HT 1 is applied to the voltage divider (between terminal 1 and 5) and divided voltage is derived at terminal ③. Between terminal ② and ④, the reference voltage is produced. The amount of error is amplified and fed back to stabilize HT 1.

The voltage divider, whose resistors are printed and trimmed, is preadjusted and fixed to obtain nominal HT 1 value. Therefore no adjustment procedure is necessary.

c) Operation Checking

Check the operation of the HV (EHT) limit circuit as described below, after the replacement is carried out.

- 1) Connect between TP-912 and TP-913 with a short link. – Fig. 4
- 2) See that the HV (EHT) limit circuit operates and HV (EHT) is ceased.
- 3) Turn off the mains switch and disconnect the short link.
- 4) See that the receiver operates normally when the set is turned on again.

3. Line oscillator circuit

Line oscillator coil (H. Hold coil-T701) is fixed with glue at the factory to prevent the H. Hold coil from being maladjusted for lower frequency resulting abnormal EHT in the receiver.

Therefore when you service the receiver, don't try to adjust or break the fixed H. Hold coil.

Please observe the following procedure when the adjustment of H. Hold is necessary.

The adjustment is required when any of the following parts have been replaced.

TR702 R715 R716 R717 R718 R721,
R758 C710, C709

Adjustment procedure

- Step. 1; Replace the fixed H. Hold Coil (T701) with new one.
- Step. 2; Turn the core of H. Hold Coil fully counter-clockwise.
- Step. 3; Turn the receiver "ON".
- Step. 4; Defeat the line synchronization by grounding the B2 terminal with a capacitor 10 μ F/50V.
- Step. 5; Obtain line synchronization by turning the core of H. Hold Coil (T701) clockwise.
- Step. 6; Turn the receiver "OFF".
- Step. 7; Release the capacitor connected at Step. 4.
- Step. 8; Fix the H. Hold Coil with glue as shown below.

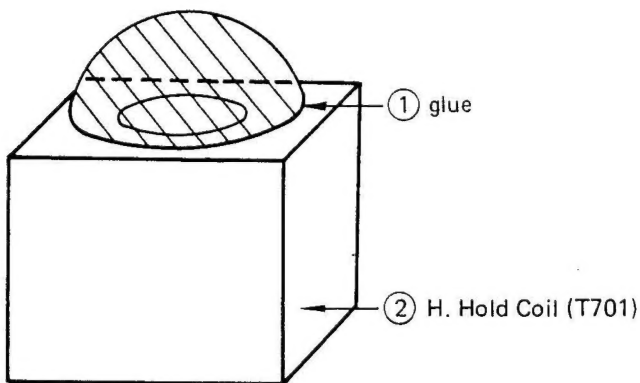

Parts name	Type No.	Parts No.	Remarks
glue	Polyamide hot melt adhesive Tru-Line No. 3 or Epoxy resin cemedine No. 1500	9485256 2784011	used at factory
glue	Epoxy resin cemedine No. 1500	2784011	used for servicing

Setp. 9; Confirm that the HV (EHT) limit circuit works correctly.

(Refer to the checking method in 2. c))

CONTROLS

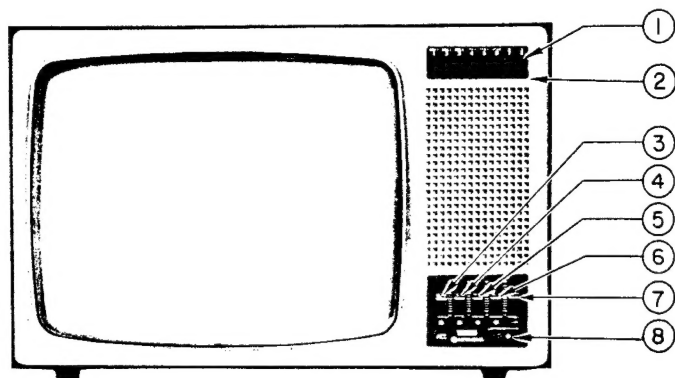

1. PROGRAMME INDICATOR
2. PROGRAMME SELECTOR
3. TINT CONTROL
4. COLOUR CONTROL
5. BRIGHTNESS CONTROL
6. CONTRAST CONTROL
7. VOLUME CONTROL

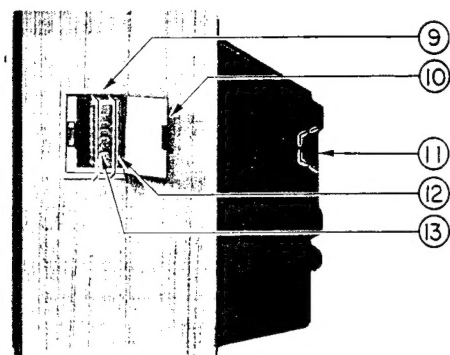

8. MAINS SWITCH
9. PROGRAMME MEMORY BOX
10. PROGRAMME MEMORY BOX LID
11. AERIAL INPUT
12. CHANNEL POINTERS
13. CHANNEL TUNING KNOBS

TECHNICAL FEATURES

1. **NEW STABILIZED POWER SUPPLY CIRCUIT (HT 1).**
HT 1 stabilizing circuit serves for stabilizing HT 1 output against supply mains fluctuations and/or load variations. In NP6C chassis, A newly developed switched mode power supply circuit is adopted.
 - (a) Fully secured against short circuit.
 - (b) Automatic shut off against faulty conditions in the line scan circuit, power supply circuit and EHT circuit.
 - (c) No adjustment for HT 1 output is necessary.
 - (d) No voltage setting against the difference of main supply voltage i.e. 240V is necessary.
 - (e) Low power consumption - - 75W.
2. **NEW COLOUR PICTURE TUBE.**
New HITACHI inline picture tube has been developed with high precision technology and skill.
 - (a) Convergence-free tube system with newly developed saddle-toroidal type scan coil.
 - (b) 76 deflection angle enables flat picture tube face.
 - (c) Sharp and crisp picture with the precision gun and the large electron lenses.
3. **NEW DIODE SPLIT TYPE LOPT.**
Newly developed diode split type LOPT is a combination of LOPT and tripler. It realizes higher efficiency and better reliability.
4. **NEW IC.**
Newly developed one-chip monolithic chroma processing IC with automatic colour contrast control function realizes enhanced colour performance.
5. **IC/TRANSISTORIZED CIRCUITS**
With the long experience of solid state technology and the developments of colour television skill, HITACHI colour television incorporates IC, transistor circuits for stable quality, less power consumption, and high reliability.
6. **QUICK START.**
Quick start colour picture tube provides "Quick Start" feature without preheating method.
After switching on the set, the picture comes out in around five seconds.
7. **HIGH RELIABILITY AND SAFETY.**
Highly printed circuits, stabilized power supply, and various protection circuits assure highly reliable receiver performance. Adjustment-free aspect on stabilized high tension and excessive EHT limit circuit assure highly safe operation.
8. **HIGH SERVICEABILITY.**
NP6C chassis consist of only two units and all components, including LOPT and power supplying circuit, are on the two units. Since this system reduced the numbers of the flying leads and connectors, better accessibility and easier diagnosis are realized.

DISASSEMBLY

1. How to remove the Power supp./DEF chassis.
 - 1) Pull the chassis straight back as in Figure.

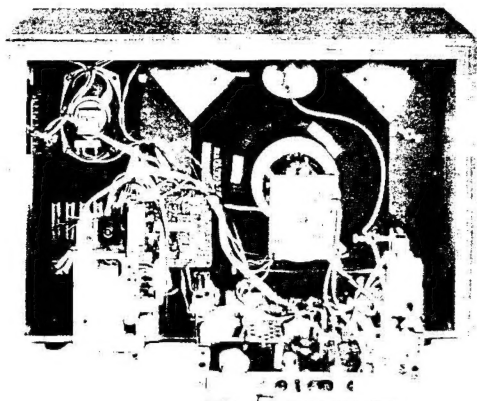

Pull the chassis straight back

3. How to remove the programm unit.
 - 1) To remove the programm unit, loosen two screws (No. ②).

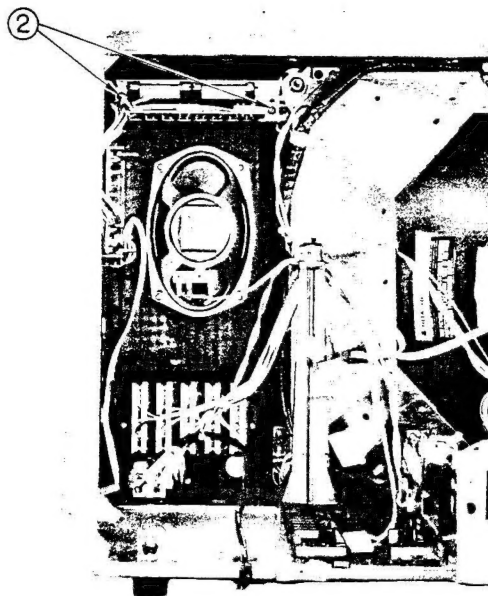

2. How to remove the chroma module.
 - 1) Releasing 1 plastic holder ①.

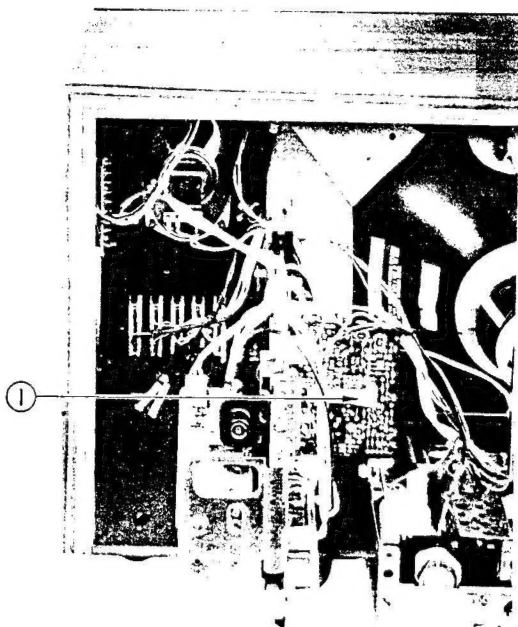

4. How to remove the speaker, control block.
 - 1) To remove the speaker, loosen four screws (No. ③).
 - 2) To remove the control block, loosen two screws (No. ④).

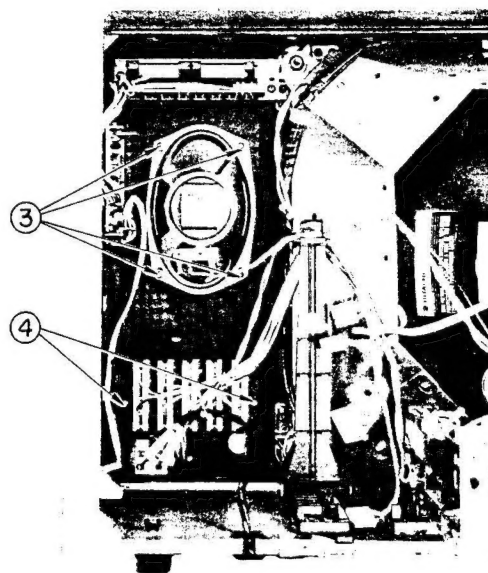

BLOCK DIAGRAM

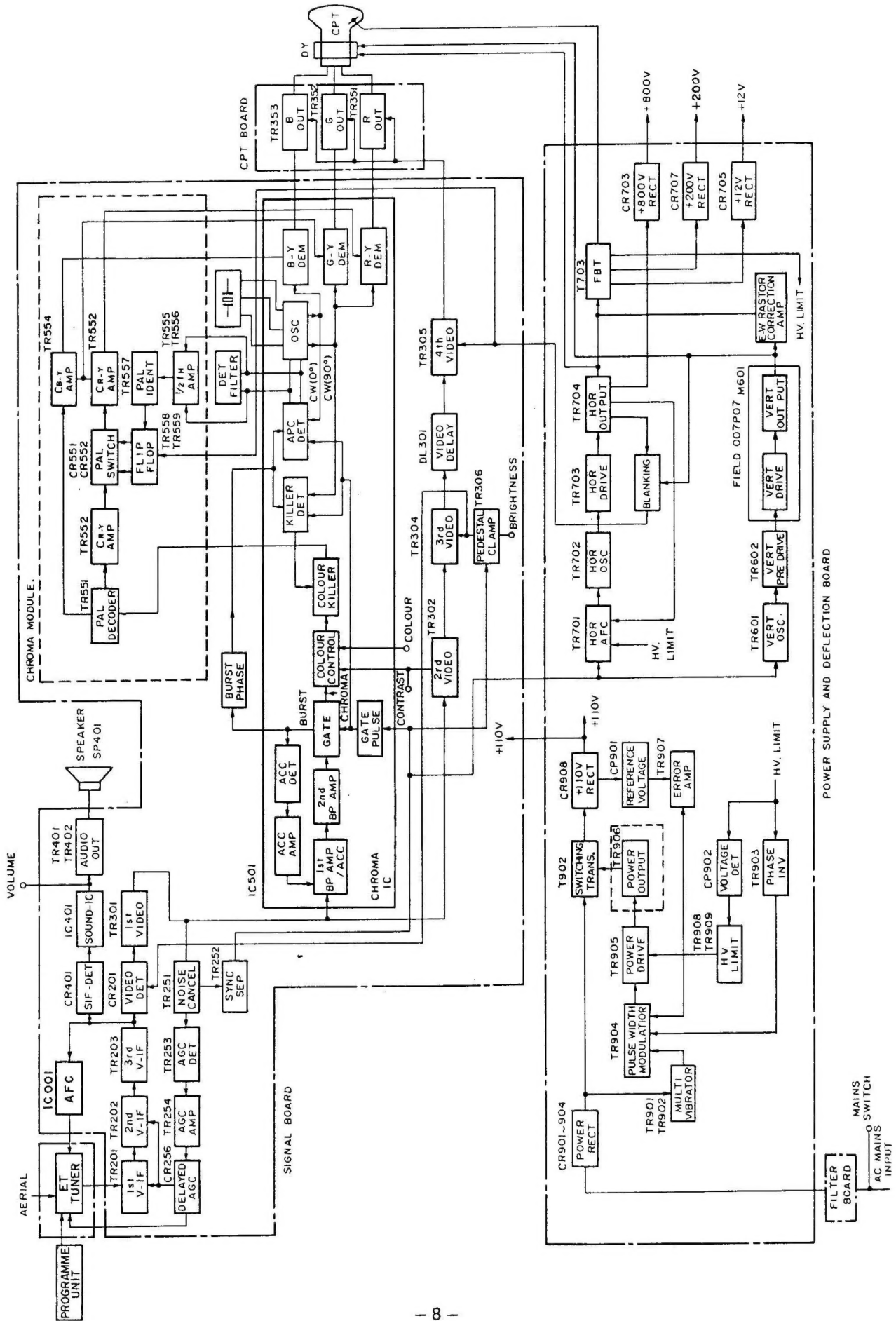

VOLTAGE SUPPLY DIAGRAM

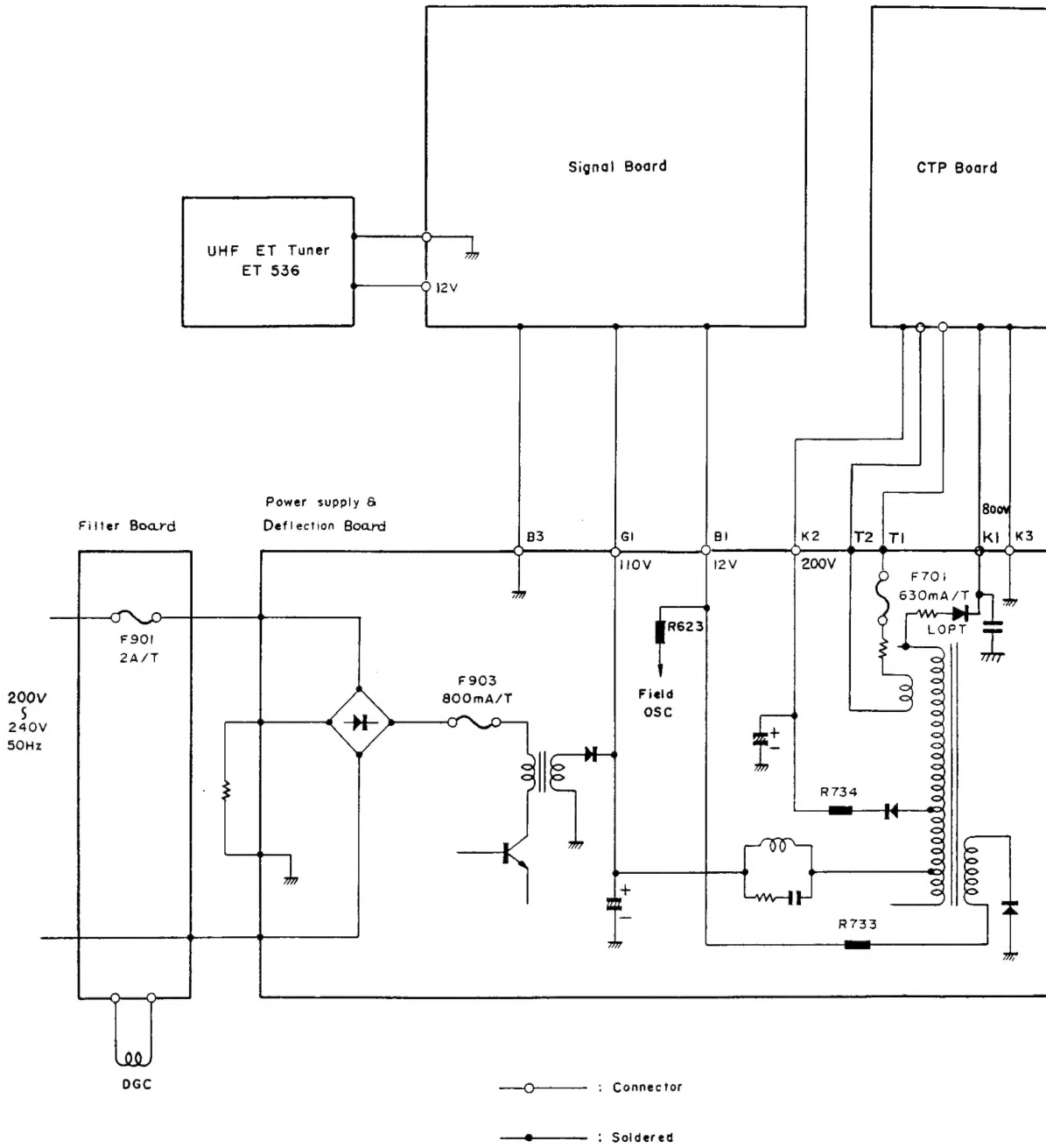

CONNECTION FOR ALIENMNT

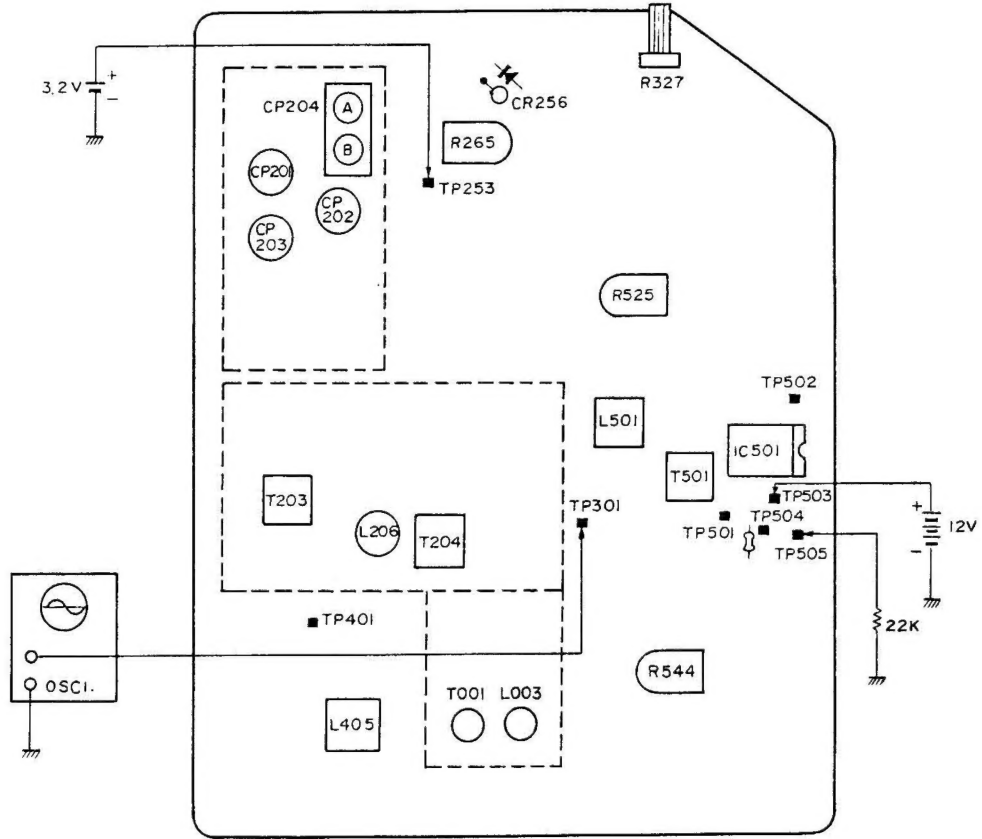

Fig. 5

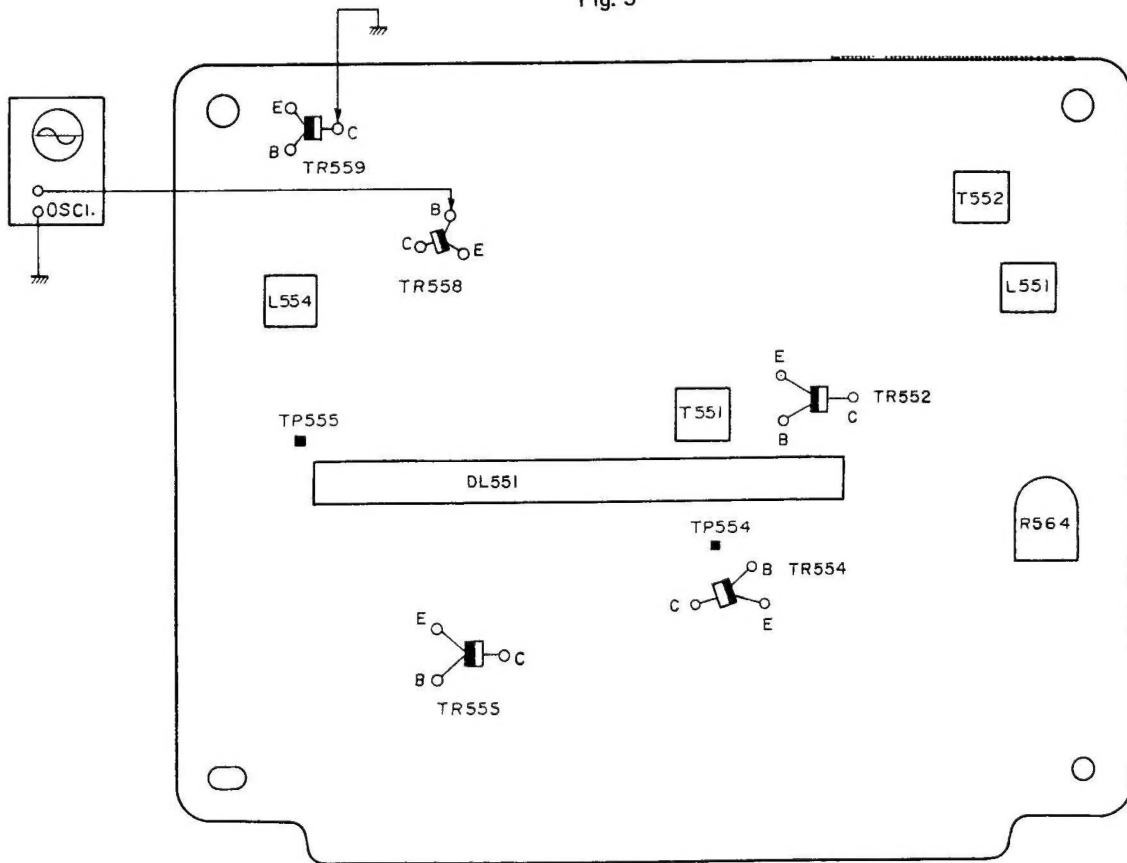

Fig. 6

PRIMARY ALIGNMENT

1. V-IF ALIGNMENT Fig. 5, 6.

- Step 1) Supply +3.2V to TP253.
- Step 2) Supply +3.2V to TP253, and +5.6V to AGC terminal for the tuner;
- Step 3) Signal generator connect to collector of TR202 through 1000pF capacitor.

Step	Signal Generator	Oscilloscope	Alignment Circuit	Alignemnt	Result	Response
1	Collector TR 202	TP 301 (Emitter TR 301)	Rejector	L 206	33.5 MHz – min .	
				T 203	Response as right	
				T 204	Response as right	
2	Tuner TP Wobbler Marker	TP 401	Rejector	CP 201	41.5 MHz – min.	
			Rejector	CP 202	31.5 MHz – min.	
			Rejector	CP 203	33.5 MHz – min.	
			CP 204	Response as right		
	TP 301 (Emitter TR 301)					

2. CHROMINANCE BANDPASS AMP. ALIGNMENT Fig. 5, 6.

- (a) Supply + 3.2V to TP253 V-IF AGC.
- (b) Connect a signal generator (Wobbler with marker and V-IF generator) to the TP-tuner.
- (c) Connect an oscilloscope the primary end of T501
- (d) Align L501 and T501 so as to obtain the response as below.

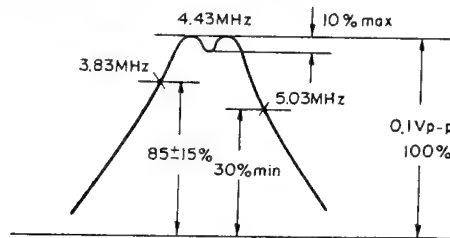

Fig. 7

note) Method of signal generator connecting for above alignment.

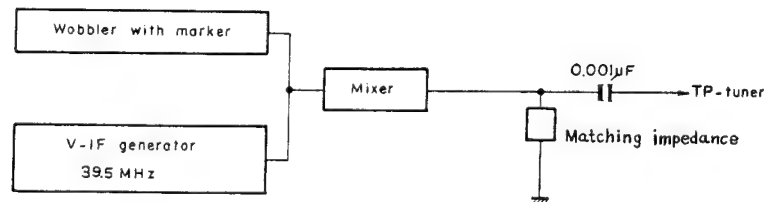

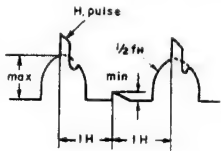

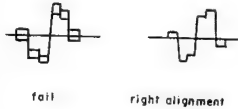

Fig. 8

3. Colour alignment Fig. 6.

3.1 Primary alignment

Step	Alignment	Oscilloscope	Aligning	Result	Note	Oscillogram
1	Reference oscillator		R 525	Obtain colour synchronization.	Supply +12V to TP 503 Ground TP 505 through a resistor 22kΩ.	
2	PAL identification	Base - TR 558	L 554	Response as right	Ground the collector of TR 559. This step should be carried out after Line frequency alignment.	
3	PAL decoder	Connector - (R - Y)	R 564 L 551 respectively	min. amplitude	only with colour-bar generator - "PAL OFF"	Refer to the next page on alignment with the electronic test card.
4	0° phase	Connector - (B - Y)	R 544	Adjust the time axis of the oscilloscope to obtain the super imposition of two lines.	Connect between both bases of TR 552 and TR 554.	
5	90° phase	Connector - (R - Y)	T 552	min. difference of succeeding lines.		

3.2 Alignment with the electronic test card . . . Fig. 9.

Step	Alignment	Aligning	Result
1	PAL decoder	L 551	min. Hannover line on part cyan
		R 564	min. Hannover line on part $+(R-Y), \pm (B-Y)$
2	0° phase	R 544	Part $+(R-Y)$ colourless
3	90° phase	T 552	Part $\pm (B-Y)$ colourless

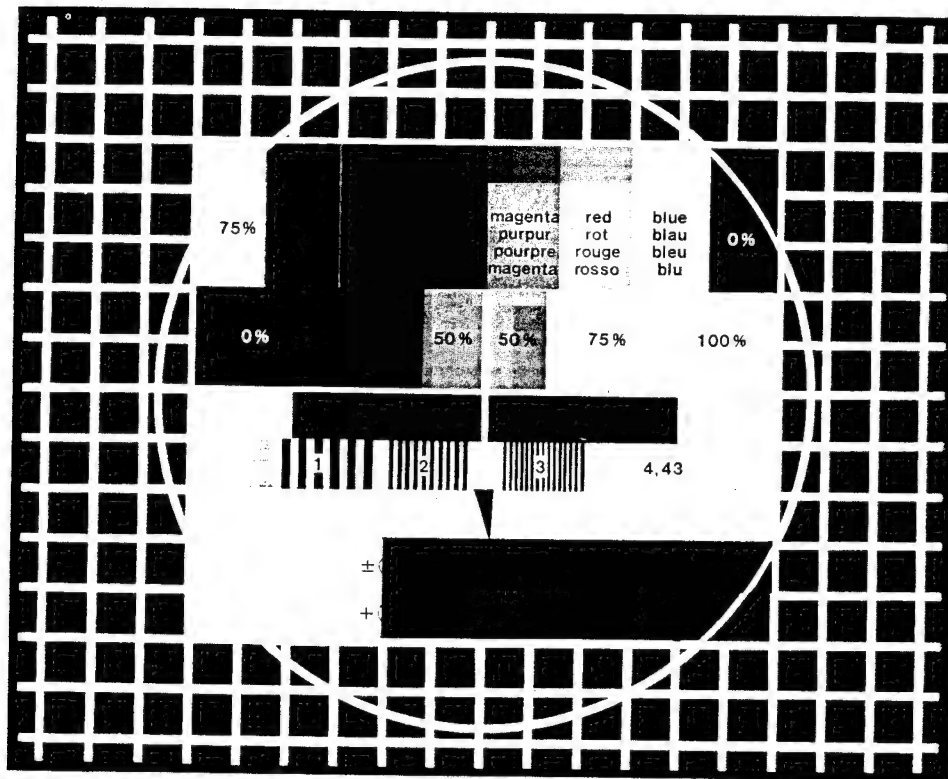

Fig. 9

4. S-IF ALIGNMENT

- (a) Connect a AM Signal Generator to TP 401 as follow. Fig. 10.

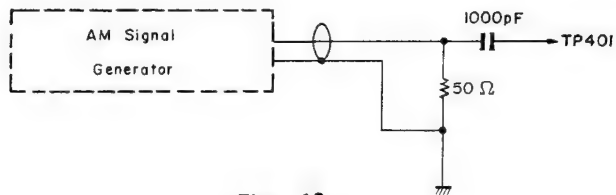

Fig. 10

- (b) Connect an osilloscope to terminal F1.
 (c) Set the AM Signal Generator as follow.
 Carrier frequency : 6.0 MHz
 Modulation : 400 Hz, 30%
 Output : -75dBm to -55dBm
 ($34\text{dB}\mu$) ($54\text{dB}\mu$)
 (d) Align L405 to obtain minimum signal.

5. AGC DELAY ALIGNMENT.

- (a) Adjust the input RF level to -56dBm .
 ($53\text{dB}\mu$)
 (b) Sock (warm up) the set at least 2 minutes.
 (c) Connect a DC-Voltmeter to the both ends of CR 256.
 (d) Align R265 so that the meter reads $0 \pm 0.1\text{V}$.

6. ALIGNMENT WITH BLACK AND WHITE PICTURE. . . Fig. 11.

- 6.1 Horizontal (Line) frequency;
 Set the R713 at the middle point. Ground the B2 terminal (on the signal board.) through a capacitor $10\mu\text{F}/50\text{V}$ and align T701 so as to obtain the correct line frequency. (See Technical PRECAUTIONS 3.)
 6.2 Picture width;
 Connect the H. SIZE link to either S,M, or L to obtain the correct picture width.
 6.3 Horizontal centering;
 Connect the H. CENT. link to either R or L to obtain the correct horizontal centering.
 6.4 Sub H. HOLD ;
 If the horizontal picture phase is shifted, adjust R713 . .
 6.5 E-W correction (Side pincushion)
 Adjust R750 so as to obtain the minimum side pincushion distortion.
 6.6 Vertical (Field) frequency ;
 Connect TP 601 with TP 603 by a resistor $15\text{k}\Omega$.
 Adjust R605 so as to obtain the correct field frequency.
 Note
 This step should be checked again after carrying out steps 6.7, 6.8, 6.9.
 6.7 Picture height :
 Adjust R 607 so as to obtain the correct picture height.
 6.8 Vertical centering ;
 Adjust R 622 so as to obtain the correct vertical centre.
 6.9 Vertical linearity ;
 Adjust R 609.
 6.10 Focus;
 Adjust R 740.

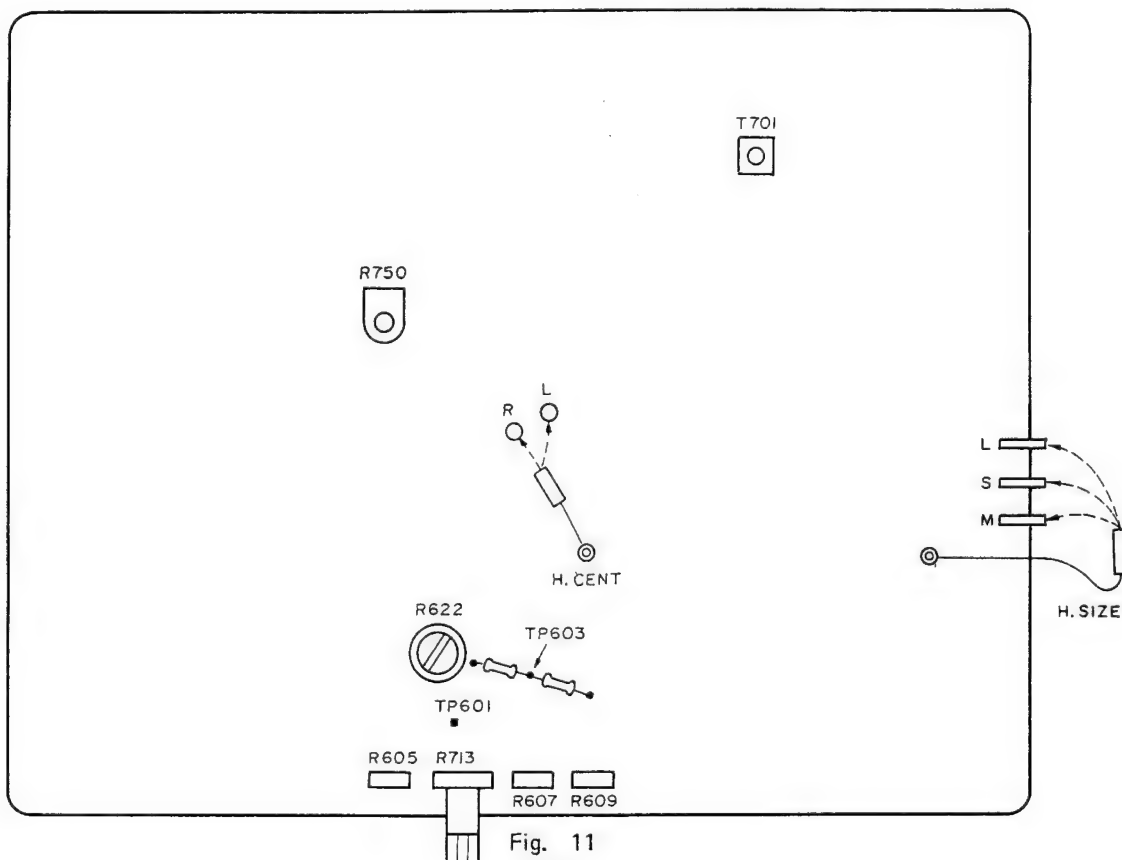

Fig. 11
 - 14 -

7. GREY SCALE TRACKING. Fig. 12.

The receiver should be soaked (warm up) at least 10 minutes before carrying out the adjustments.

Set the tint control at its middle position.

- (a) Receive a white raster test card and set the Drive controls (R 857 & R 863) at their middle positions.
- (b) Turn the Back Ground Level (BGL) controls (R 865, R 859 & R 853) fully counterclockwise. (The picture will be darkened.)
- (c) Turn the Screen control (R 872) fully counterclockwise.
- (d) Set the Contrast control at its minimum.
- (e) Disconnect the Y-connector from the signal board and connect TP 602 with TP 603 with a short link. (Field oscillator defeats.)
- (f) Turn up the Screen control (R872) gradually until one of three coloured lines faintly appears on the screen. (e.g. blue)
Unless any coloured line comes out, turn the Screen control fully clockwise, then adjust the Blue-, Red- and Green-BGL controls so that three coloured lines equally appears on the screen.
- (g) Keep one of the BGL-controls which corresponds to above colour (e.g. Blue-BGL R 865) at it is, and turn up other two controls (e.g. R 853, and R 859) until their coloured lines also faintly appear on the screen.
- (h) Disconnect the short link from TP 602 and TP 603 (Field oscillator operates.), and connect the Y-connector to the signal board.
- (i) Turn the Contrast control fully counterclockwise and turn the Brightness control fully counterclockwise. Set the Sub-brightness control (R 327) so that the white raster faintly appears on the screen.
- (j) Adjust those two BGL-controls (e.g. R 853 and R 859) so that the correct grey scale tracking at low brightness is obtained.
- (k) Turn up the Contrast control and adjust the Drive controls (R 857 and R 863) so that the correct grey scale tracking at high brightness is obtained.
- (l) Turn down the Contrast control and check the correct grey scale tracking at low brightness. Otherwise readjust those two BGL-controls (e.g. R 853 and R 859) for the correct grey scale tracking.
- (m) Repeat steps (k) and (l) several times, until the ideal grey scale tracking is obtained under whole brightness range.

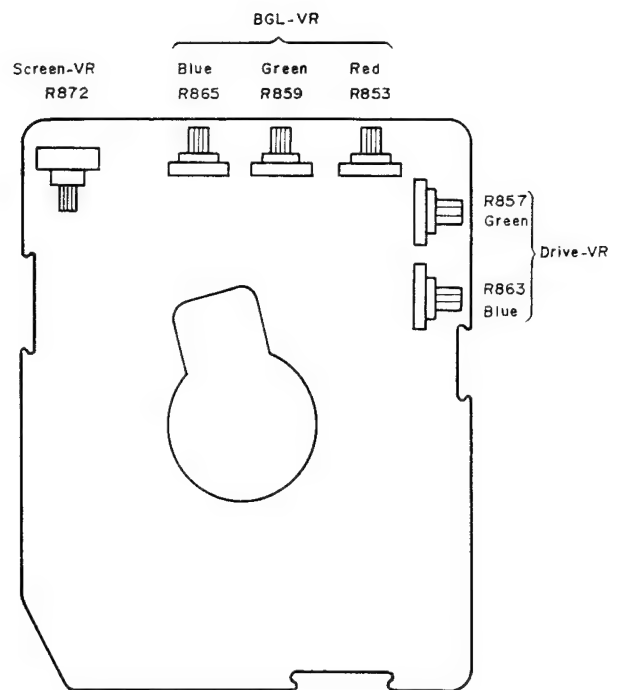

Fig. 12

8. SUB BRIGHTNESS ALIGNMENT.Fig. 13

- (a) Set the Brightness control at its middle position and the contrast control at its minimum.
- (b) Release the field locking by V. hold control (R605) and let the blanking aprt appear on the screen and stand still as possible as you can.
- (c) Observe the black level of part A, and turn up the Sub brightness control (R 327) gradually until that level can be noticed to turn grey.

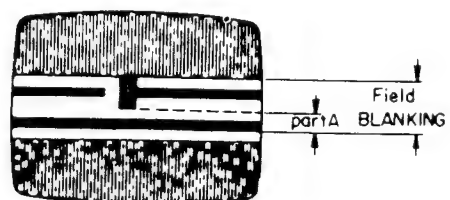

Fig. 13

9. CONVERGENCE ALIGNMENT.Fig. 14

1) NP6C chassis television receiver incorporates new colour picture tube system, i.e. HITACHI. flat face inline type tube, saddle-troidal scan coil and convergence-free features.

Since the convergence quality is strictly controlled in the factory and to be secured its performance after installation, the reconvergence is not normally required.

When it is needed in case of the replacement of a picture tube or a scan coil etc., please read and follow the the adjustment procedure step by step to obtain the best results, because this is rather different from the conventional tube system.

- 2) Set the television receiver facing to the south, and soak it at least 10 mins.
Check the horizontal and vertical linearity, the picture width, and the focus as already described on the previous pages.
Receive a cross-hatch test card.
- 3) In case of the replacement fo the picture tube, wind the adhesive tape (bandage type is preferable) around the neck, for securing purpose of scan coil.

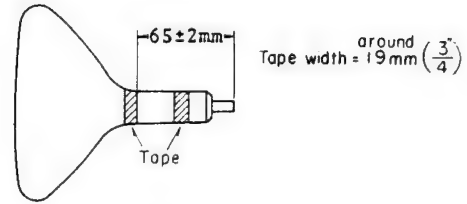

Fig. 14

10. PURITY ALIGNMENT Fig. 15, 16. 17

As before proceeding the below, please undergo preliminary static convergence adjustment on this page.

- 1) Push the scan coil fully up to funnel part of the picture tube. Disconnect the (G-Y) plug from the signal board and see the broad mazenata belt appears on the screen . . . Fig. 15 (a).
- 2) Pull out the scan coil gradually towards you and see that two oval parts (coloured pale yellow and light blue) appear on each side of the screen . . . Fig. 15 (b).
- 3) Rotate the purity magnet (c) (Fig. 16), and set two coloured parts to become equal in area. . . Fig. 15(c).
- 4) Insert preliminary rubber wedge between the funnel and the scan coil at the top position, and tilt the scan coil backward at the top.
- 5) Pull out the scan coil gradually towards you again until two coloured parts disappear simultaneously. See that the white purity (connect (G-Y) plug) is all right, if not, pull out the scan coil until ideal white purity is obtained. Fasten the scan coil securely by tightening the screw
- 6) Unless the red purity (disconnect both (G-Y), (B-Y) plugs) is obtained, repeat the steps 2) ~ 5) again.

Note) Put the purity-convergence magnet assembly on the picture tube neck, so that the edge of tightning ring isolated 32 mm from the tip of the neck. . . Fig. 16.
Secure it firmly by tightning the screw.

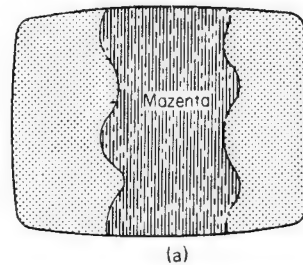

(a)

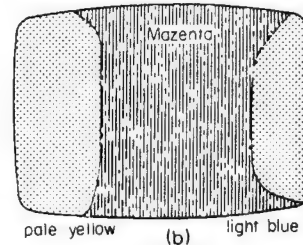

(b)

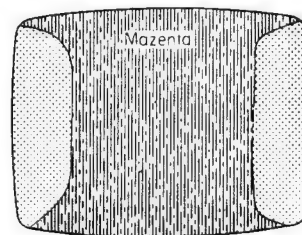



(c)

Fig. 15

11. STATIC CONVERGENCE ALIGNMENT. . . . Fig. 16 and Fig. 17.

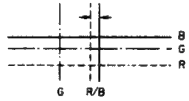
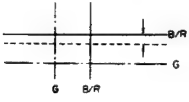
This procedure is the convergence alignment for the centre part of the screen.

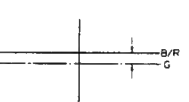
Step	Convergence lines	Magnet (Fig. 16)	Movement (Fig. 17)	Centre of the screen
1	Vertical Blue and Red	4 poles (A)	sliding (a)	
2	Horizontal Blue and Red	4 poles (A)	rotating (b)	
3	Vertical B/R and Green	6 poles (B)	sliding (a)	
4	Horizontal B/R and Green	6 poles (B)	rotating (b)	
5	Repeat steps 1) through 4).			
6	If the correct convergence is not obtainable after carrying out the steps 1) through 5) above, displace the purity-convergence magnet assembly along the neck of the picture tube within the range of ± 5 mm and repeat steps 1) through 5).			

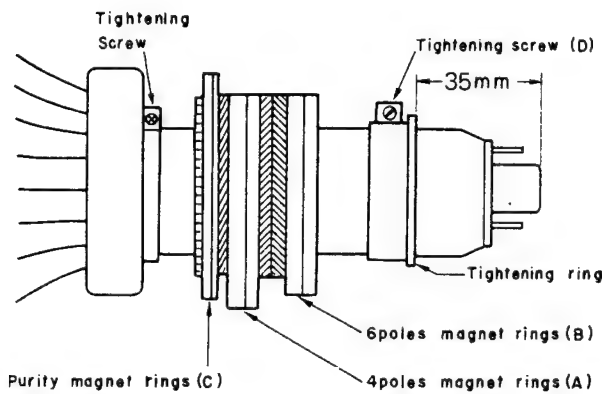

Fig. 16

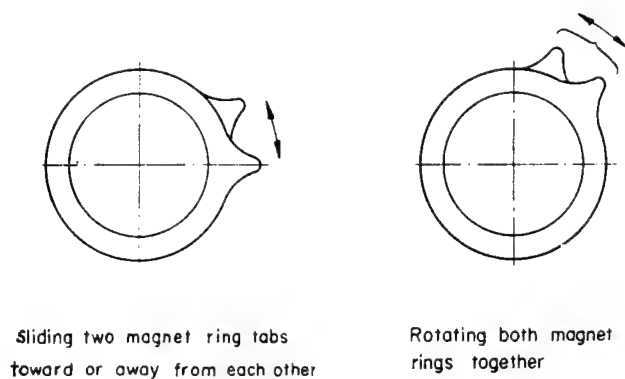

Fig. 17

12. DYNAMIC CONVERGENCE ALIGNMENT

This procedure is the convergence alignment for the circumference of the screen.

- 1) Push in the preliminary rubber wedge between the funnel part and scan coil gradually until both horizontal and vertical lines are converged at the circumference of the screen. . . Fig. 18.

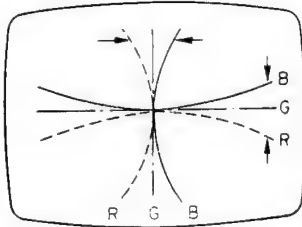
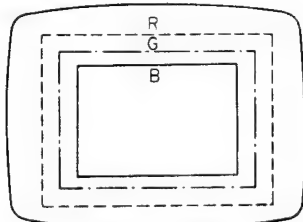

Fig. 18

- 2) Proceed the either case according to the arrangements on the screen. . . Fig. 19 (a) and (b).

CASE (a)



(a)

CASE (b)

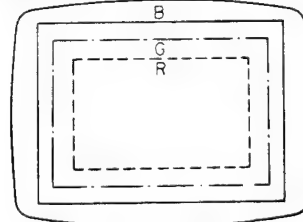

(b)

Fig. 19

CASE (a)

- i) Insert fixing wedge at 9 o'clock position, until three coloured squares are converged.
- ii) Insert two fixing wedges at 1 and 5 o'clock positions and fix three wedges by highly adhesive tape. Then pull up preliminary wedge.

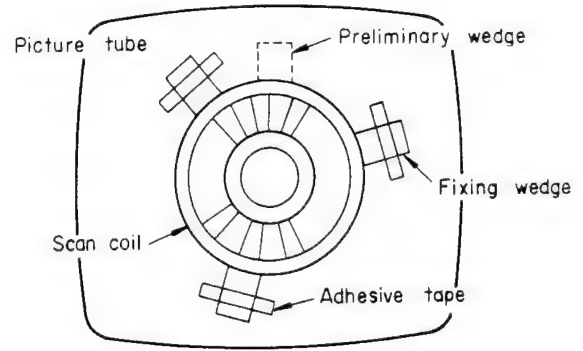

(a)

Fig. 20

CASE (b)

- i) Insert fixing wedge at 3 o'clock position, until three coloured squares are converged.
- ii) Insert two fixing wedges at 7 and 11 o'clock positions and fix three wedges by highly adhesive tape. Then pull up the preliminary wedge.

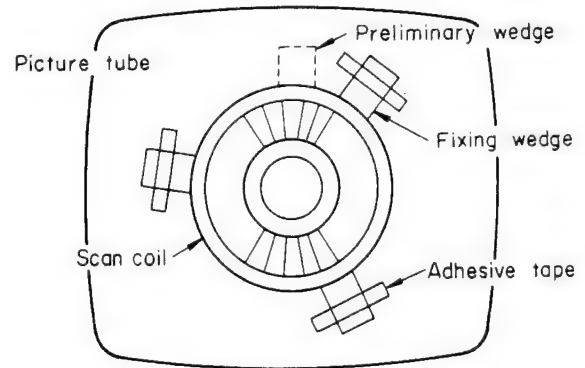

(b)

Fig. 21

PRINTED WIRING BOARD DIAGRAM SIGNAL BOARD

- +B PATTERN
- SIGNAL PATTERN
- GROUND PATTERN

+12V PATTERN

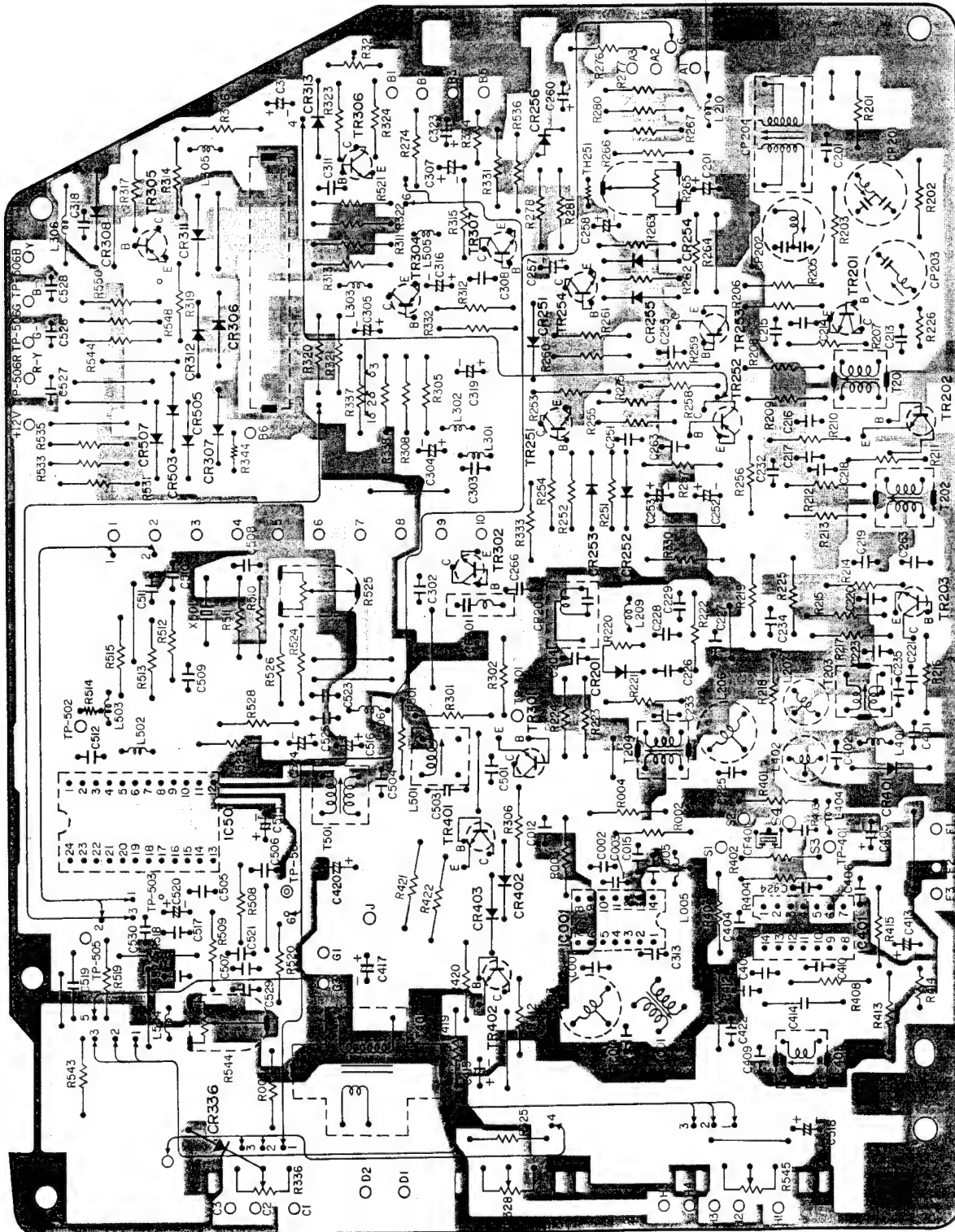

CHROMA MODULE

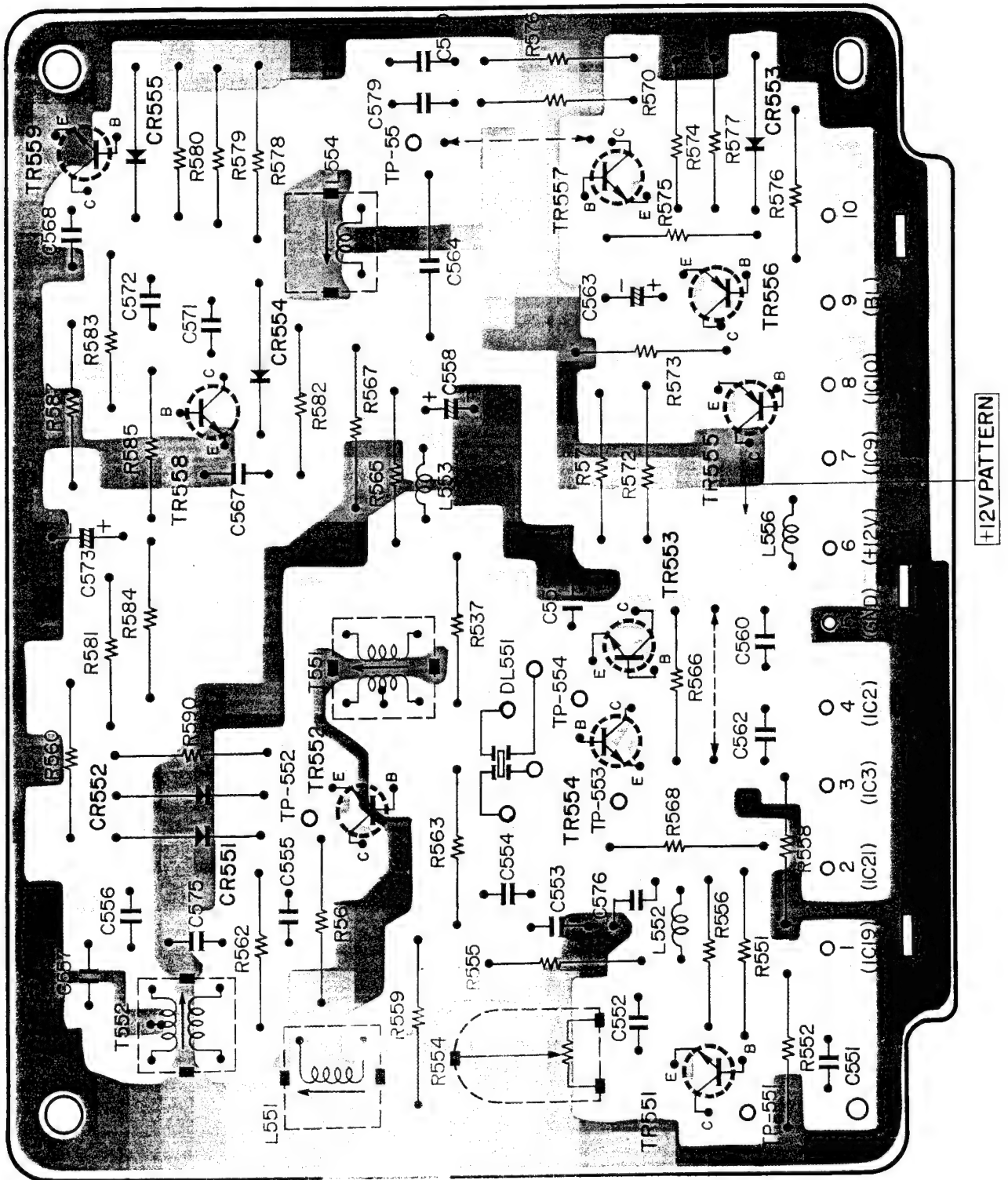

C.P.T. BOARD

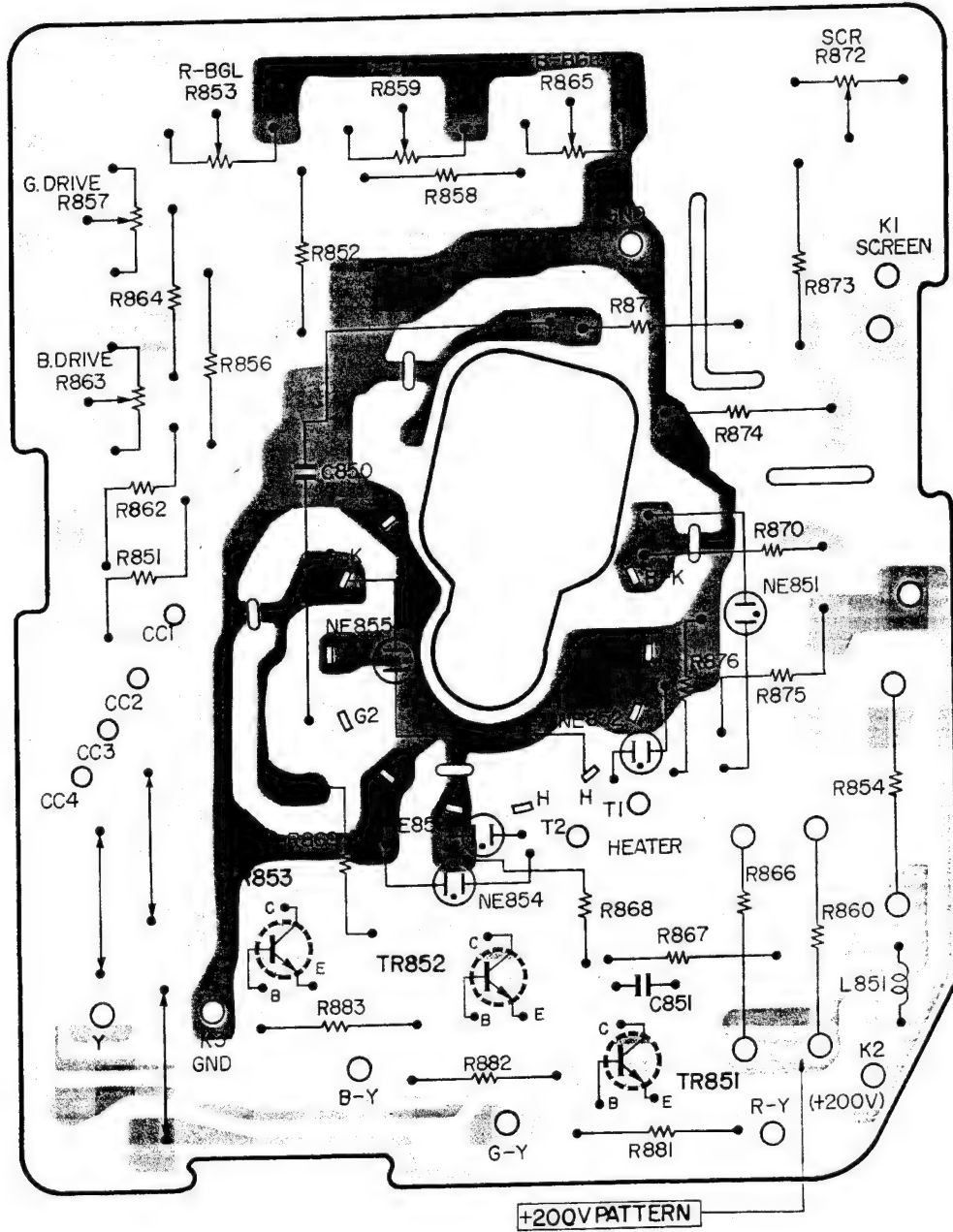

TUNER CIRCUIT SCHEMATIC DIAGRAM (ET-536)

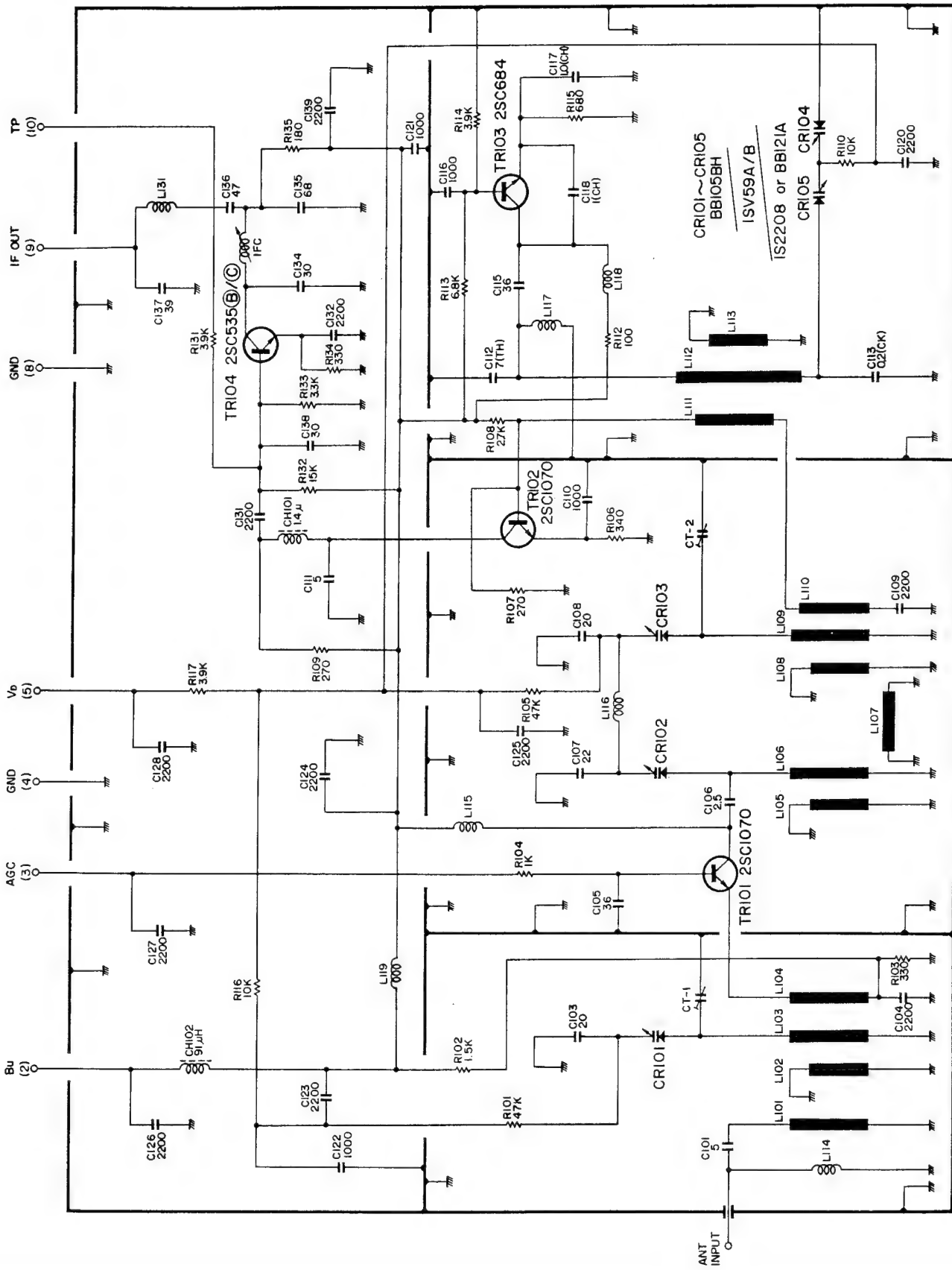

PUSH BOTTOM SELECTOR CIRCUIT (HP-538)

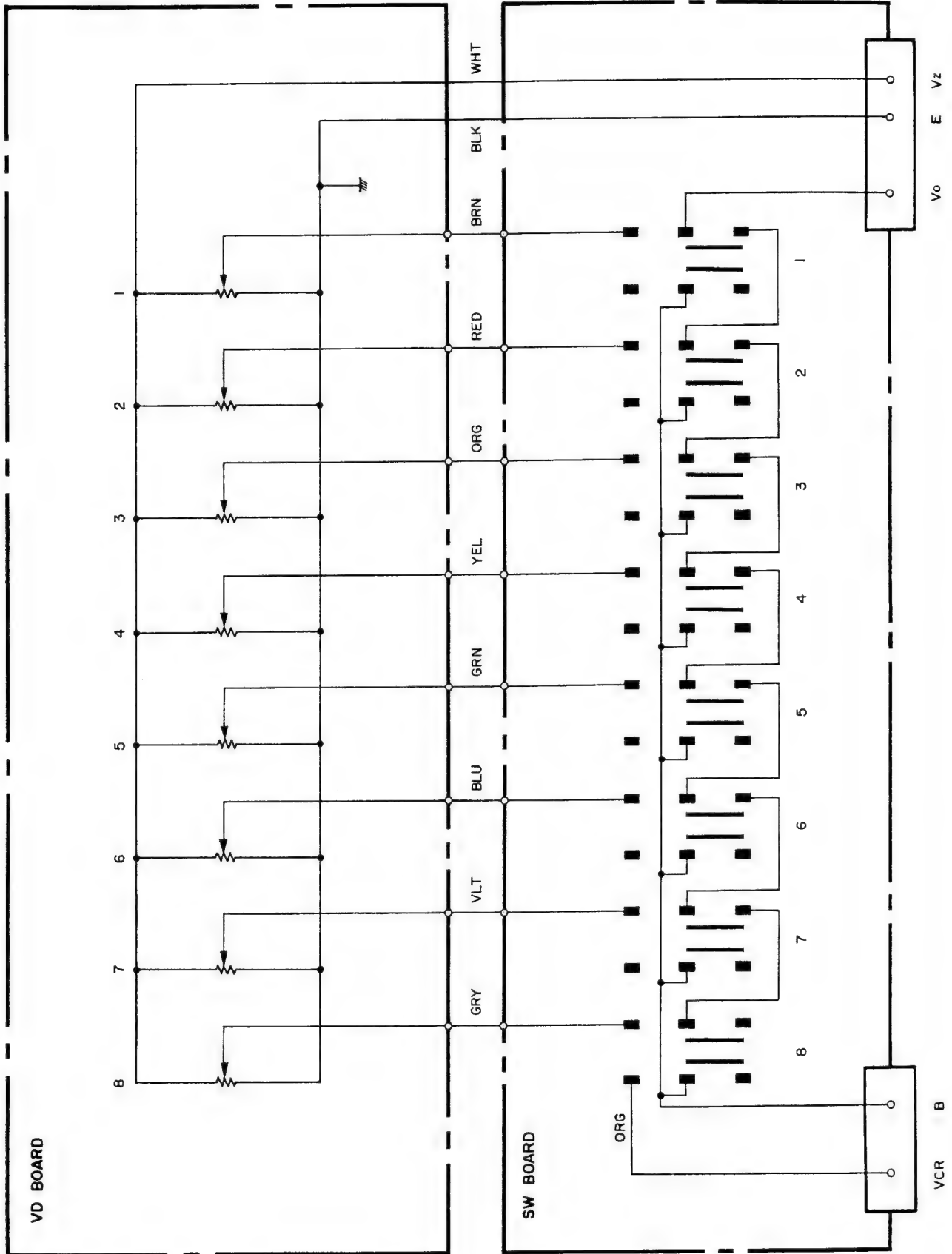

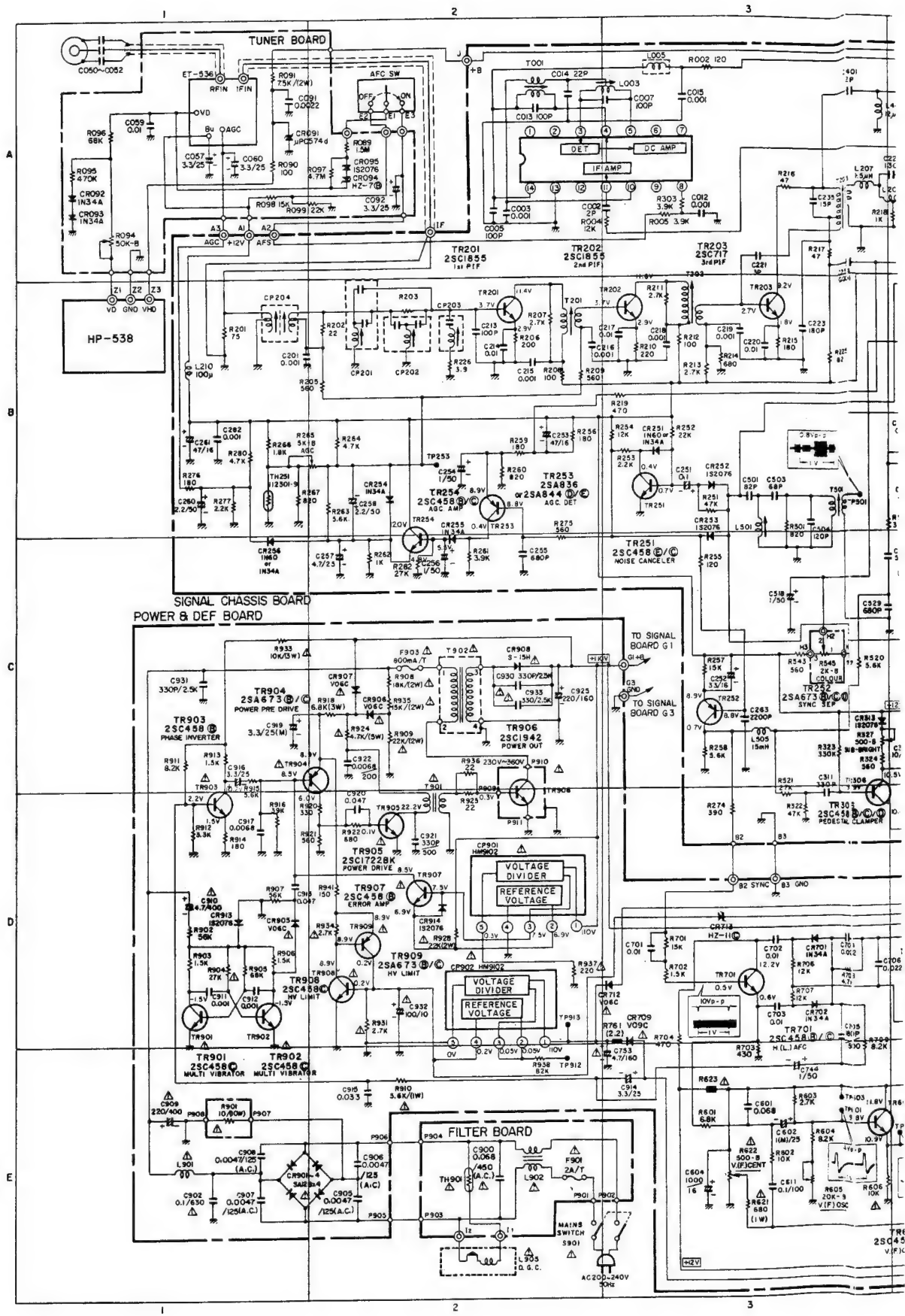

BASIC CIRCUIT SCHEMATIC DIAGRAM (CTP-203)

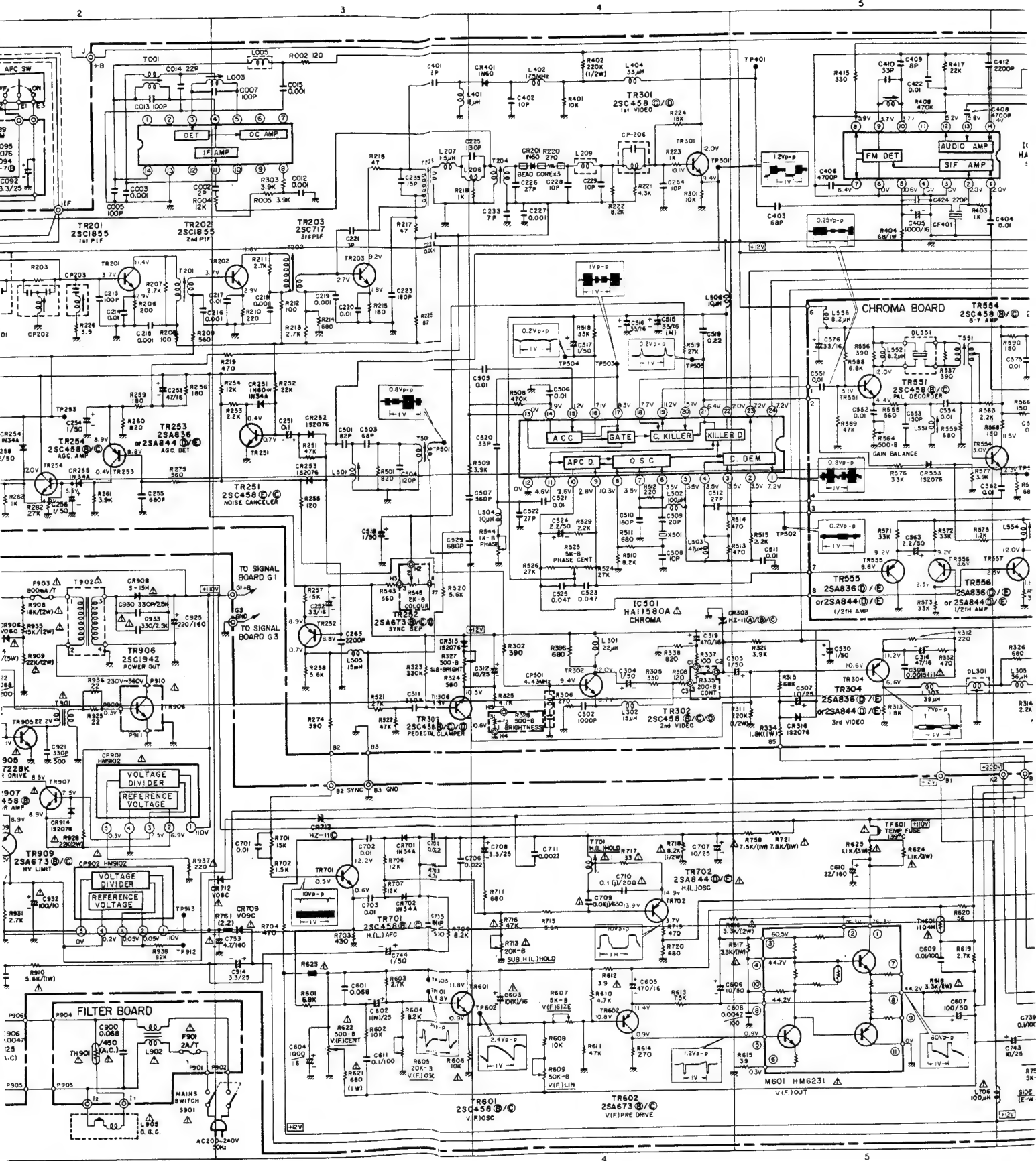

SCHEMATIC DIAGRAM (CTP-203)

Components marked with a Δ components, read carefully the improper servicing.

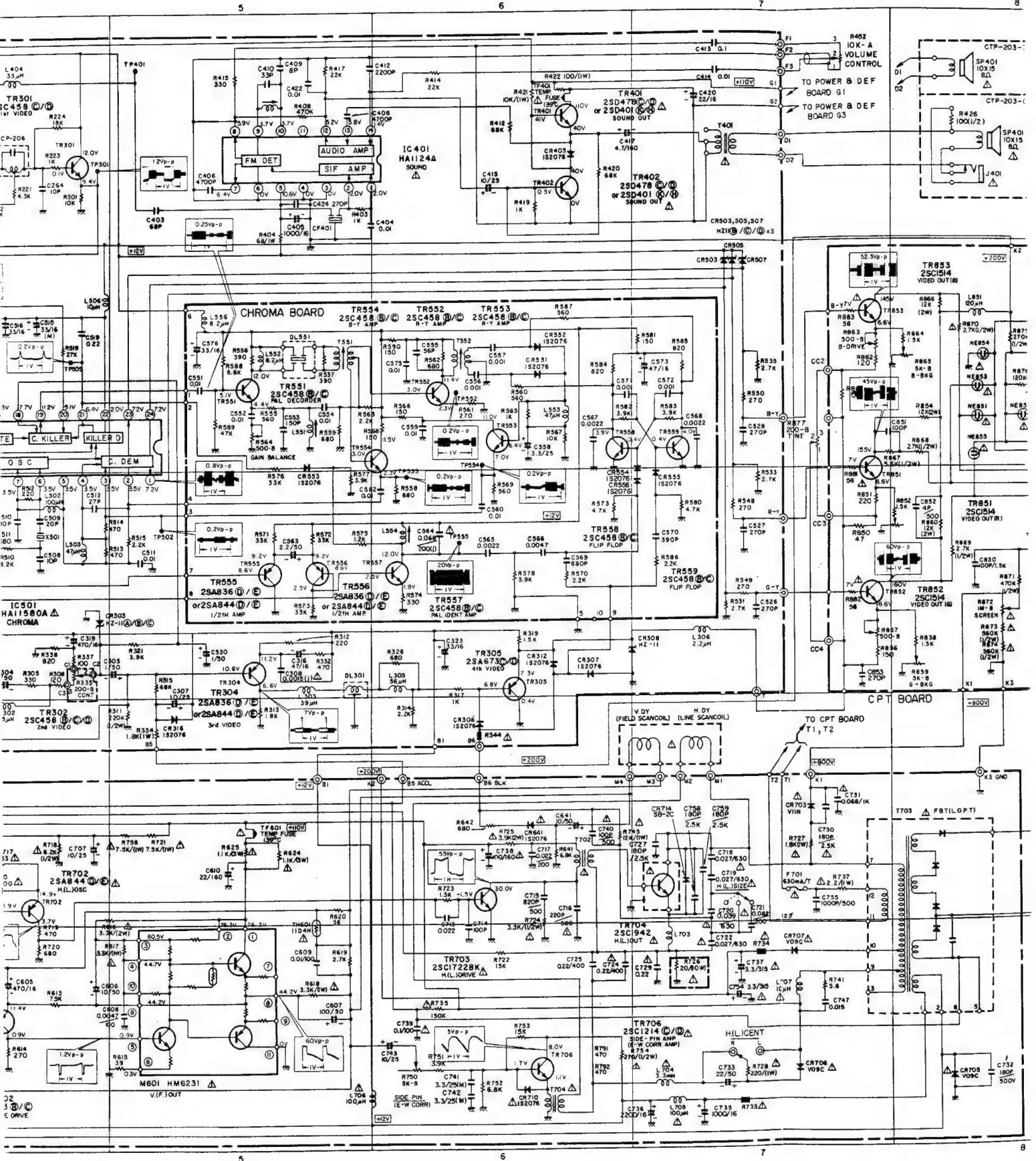

PRODUCT SAFETY NOTE

Components marked with a Δ and shaded have special characteristics important to safety. Before replacing any of these components, read carefully the "Product safety notices" of this service manual. Don't degrade the safety of the receiver through improper servicing.

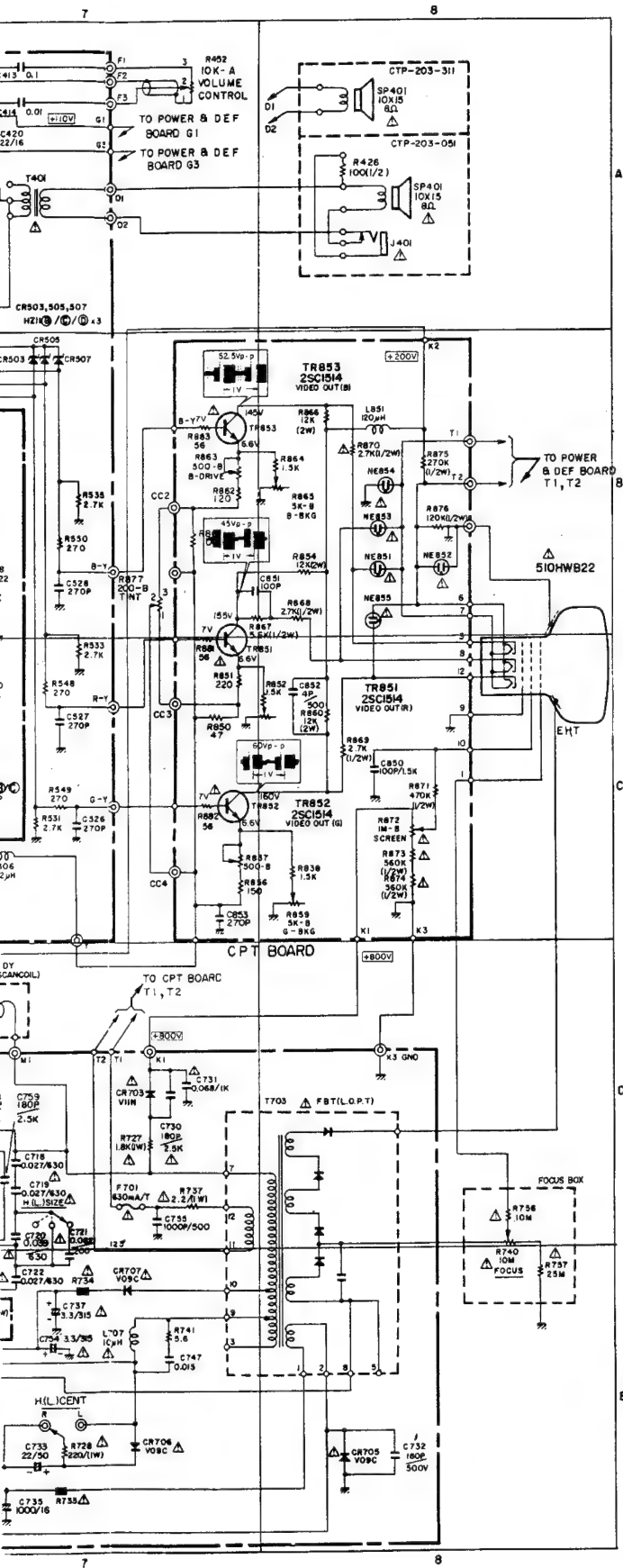

IMPORTANT

The component shaded in red is sealed at the factory. No attempt shall be made to adjust or defeat T701. Refer to Page 5 in Service Manual when it is necessary to adjust the sealed component during servicing.

- Since this is a basic circuit diagram, the value of the parts is subject to be altered for improvement.
 - All DC voltage to be measured with a tester (100K Ω /V).
- Voltages taken on a complex colour bar signal including a standard colour bar signal.

REPLACEMENT PARTS LIST

PLACE	SYM-BOL NO.	STOCK NO.	DESCRIPTION	PLACE	SYM-BOL NO.	STOCK NO.	DESCRIPTION
CAPACITORS				C4	C319	0252565	Electrolytic 470 μ F DC16WV
A2	C002	0248632	Ceramic 2pF \pm 0.25pF DC50WV	C6	C323	0252523	Electrolytic 33 μ F DC16WV
A2	C003	0244101	Ceramic 1.000pF \pm 10% DC50WV	A3	C401	0248632	Ceramic 2pF \pm 0.25pF DC25WV
A2	C005	0248684	Ceramic 100pF \pm 5% DC50WV	A3	C402	0248650	Ceramic 10pF \pm 0.5pF DC50WV
A2	C007	0249043	Ceramic 100pF \pm 5% DC50WV	A5	C403	0248680	Ceramic 68pF \pm 5% DC50WV
A2	C012	0244101	Ceramic 1.000pF \pm 10% DC50WV	A5	C404	0244171	Ceramic 0.01 μ F \pm 5% DC50WV
A2	C013	0249043	Ceramic 100pF \pm 5% DC50WV	A5	C405	0252536	Electrolytic 1.000 μ F DC16WV
A2	C014	0248668	Ceramic 22pF \pm 5% DC50WV	A5	C406	0244109	Ceramic 4.700pF \pm 10% DC50WV
A2	C015	0244101	Ceramic 1.000pF \pm 10% DC50WV	A5	C408	0244109	Ceramic 4.700pF \pm 10% DC50WV
A1	C058	0252613	Electrolytic 3.3 μ F DC25WV	A5	C409	0246418	Ceramic 8pF \pm 0.25pF DC50WV
A1	C059	0277013	Polyester film 0.01 μ F \pm 10% DC50WV	A5	C410	0248182	Ceramic 33pF \pm 5% DC50WV
A1	C060	0252613	Electrolytic 3.3 μ F DC25WV	A5	C412	0244105	Polyester 2.200pF \pm 5% DC50WV
A1	C091	0244105	Ceramic 0.0022 μ F \pm 10% DC50WV	A7	C413	0277025	Polyester 0.1 μ F \pm 10% DC50WV
A1	C092	0252613	Electrolytic 3.3 μ F DC25WV	A7	C414	0277013	Polyester 0.01 μ F \pm 10% DC50WV
B1	C201	0244101	Ceramic 1.000pF \pm 10% DC50WV	A6	C415	0252821	Electrolytic 10 μ F DC25WV
B1	C210	0252817	Electrolytic 2.2 μ F DC50WV	A6	C417	0257537	Electrolytic 4.7 μ F DC160WV
B2	C213	0248684	Ceramic 100pF \pm 5% DC50WV	A7	C420	0258585	Electrolytic 22 μ F DC160WV
B2	C214	0244141	Ceramic 0.01 μ F \pm 10% DC50WV	A5	C422	0277013	Polyester 0.01 μ F \pm 10% DC50WV
B2	C215	0244101	Ceramic 1.000pF \pm 10% DC50WV	A5	C424	0244136	Ceramic 270pF \pm 10% DC50WV
B2	C216	0244101	Ceramic 1.000pF \pm 10% DC50WV	B3	C501	0248682	Ceramic 82pF \pm 5% DC50WV
B2	C217	0244141	Ceramic 0.01 μ F \pm 10% DC50WV	B3	C503	0248680	Ceramic 68pF \pm 5% DC50WV
B2	C218	0244101	Ceramic 1.000pF \pm 10% DC50WV	B3	C504	0248686	Ceramic 120pF \pm 5% DC50WV
B3	C219	0244101	Ceramic 1.000pF \pm 10% DC50WV	B3	C505	0244171	Ceramic 0.01 μ F \pm 5% DC50WV
B3	C220	0244141	Ceramic 0.01 μ F \pm 10% DC50WV	B4	C506	0244171	Ceramic 0.01 μ F \pm 5% DC50WV
A3	C221	0246413	Ceramic 3pF \pm 0.25pF DC50WV	C3	C507	0248698	Ceramic 560pF \pm 5% DC50WV
B3	C223	0248690	Ceramic 180pF \pm 5% DC50WV	C4	C508	0248650	Ceramic 10pF \pm 0.5pF DC50WV
A3	C225	0249043	Ceramic 100pF \pm 5% DC50WV	C4	C509	0246447	Ceramic 20pF \pm 5% DC50WV
A3	C226	0248340	Ceramic 27pF \pm 5% DC50WV	C4	C510	0249094	Ceramic 180pF \pm 5% DC50WV
A3	C227	0244101	Ceramic 1.000pF \pm 10% DC50WV	C4	C511	0244171	Ceramic 0.01 μ F \pm 5% DC50WV
A4	C228	0248650	Ceramic 10pF \pm 0.5% DC50WV	C4	C512	0248670	Ceramic 27pF \pm 5% DC50WV
A4	C229	0248650	Ceramic 10pF \pm 0.5p DC50WV	B4	C515	0259808	Electrolytic 33 μ F DC16WV
B1	C232	0277013	Polyester 0.01 μ F \pm 10% DC50WV	B4	C516	0252523	Electrolytic 33 μ F DC16WV
A3	C233	0248637	Ceramic 7pF \pm 0.25pF DC50WV	B4	C517	0252811	Electrolytic 1 μ F DC50WV
A3	C235	0248034	Ceramic 15pF \pm 5% DC50WV	C3	C518	0252811	Electrolytic 1 μ F DC50WV
B3	C251	0277025	Polyester 0.1 μ F \pm 10% DC50WV	B4	C519	0277029	Polyester 0.22 μ F \pm 10% DC50WV
C3	C252	0252523	Electrolytic 33 μ F DC16WV	B3	C520	0248672	Ceramic 33pF \pm 5% DC50WV
B2	C253	0252525	Electrolytic 47 μ F DC16WV	C4	C521	0244171	Ceramic 0.01 μ F \pm 5% DC50WV
B2	C254	0252811	Electrolytic 1 μ F DC500WV	C3	C522	0248670	Ceramic 27pF \pm 5% DC50WV
C2	C255	0244117	Ceramic 680pF \pm 10% DC50WV	C4	C523	0277021	Polyester 0.047 μ F \pm 10% DC50WV
C2	C256	0251087	Electrolytic 1 μ F DC25WV	C4	C524	0252817	Electrolytic 2.2 μ F DC50WV
C1	C257	0252615	Electrolytic 4.7 μ F DC25WV	C4	C525	0277021	Polyester 0.047 μ F \pm 10% DC50WV
B1	C258	0252522	Electrolytic 22 μ F DC16WV	C7	C526	0244136	Ceramic 270pF \pm 10% DC50WV
B1	C260	0252817	Electrolytic 2.2 μ F DC50WV	B7	C527	0244136	Ceramic 270pF \pm 10% DC50WV
B1	C261	0252525	Electrolytic 47 μ F DC16WV	B7	C528	0244136	Ceramic 270pF \pm 10% DC50WV
C3	C264	0248650	Ceramic 10pF \pm 0.5pF DC50WV	C3	C529	0244117	Ceramic 680pF \pm 10% DC50WV
A4	C263	0277005	Ceramic 2.200pF \pm 10% DC50WV	C5	C530	0252811	Electrolytic 1 μ F DC50WV
B3	C266	0248690	Ceramic 180pF \pm 5% DC50WV	B5	C551	0244171	Ceramic 0.01 μ F \pm 5% DC50WV
B1	C282	0244101	Ceramic 1.000pF \pm 10% DC50WV	B5	C552	0244171	Ceramic 0.01 μ F \pm 5% DC50WV
D4	C302	0244101	Ceramic 1.000pF \pm 10% DC50WV	B5	C553	0248688	Ceramic 150pF \pm 5% DC50WV
C4	C303	0248676	Ceramic 47pF \pm 5% DC50WV	B5	C554	0244171	Ceramic 0.01 μ F \pm 5% DC50WV
C4	C304	0252811	Electrolytic 1 μ F DC50WV	B6	C555	0248678	Ceramic 56pF \pm 5% DC50WV
C4	C305	0252811	Electrolytic 1 μ F DC50WV	B6	C556	0244101	Ceramic 1.000pF \pm 10% DC50WV
C4	C307	0252621	Electrolytic 10 μ F DC25WV	B6	C557	0244101	Ceramic 1.000pF \pm 10% DC50WV
△ C5	C308	0275023	Polyester 1.500pF \pm 5% DC50WV	B6	C558	0252613	Electrolytic 3.3 μ F DC25WV
C3	C311	0248696	Ceramic 330pF \pm 5% DC50WV	B6	C559	0244171	Ceramic 0.01 μ F \pm 5% DC50WV
C3	C312	0252621	Electrolytic 10 μ F DC25WV	C6	C560	0244171	Ceramic 0.01 μ F \pm 5% DC50WV
C4	C316	0252525	Electrolytic 47 μ F DC16WV	B5	C561	0244171	Ceramic 0.01 μ F \pm 5% DC50WV
C6	C318	0244101	Ceramic 1.000pF \pm 10% DC50WV	C5	C562	0244171	Ceramic 0.01 μ F \pm 5% DC50WV
				C5	C563	0252817	Electrolytic 2.2 μ F DC50WV
				△ C6	C564	0299959	Polypropylene 0.068 μ F \pm 5% DC200WV

PRODUCT SAFETY NOTE – Components marked with a Δ have special characteristics important to safety. Before replacing any of these components, read carefully, the PRODUCT SAFETY NOTICE of this Service Manual. Don't degrade the safety of the receiver through improper servicing.

PLACE	SYM-BOL NO.	STOCK NO.	DESCRIPTION			PLACE	SYM-BOL NO.	STOCK NO.	DESCRIPTION		
C6	C565	0244105	Ceramic	2.200pF $\pm 10\%$	DC50WV	E5	C743	0252621	Electrolytic	10 μ F	DC25WV
C6	C566	0244109	Ceramic	4.700pF $\pm 10\%$	DC50WV	E3	C744	0252811	Electrolytic	1 μ F	DC50WV
B6	C567	0244105	Ceramic	2.200pF $\pm 10\%$	DC50WV	E7	C747	0277015	Ceramic	0.015 μ F	DC50WV
B7	C568	0244105	Ceramic	2.200pF $\pm 10\%$	DC50WV	Δ E2	C753	0257537	Electrolytic	4.7 μ F	DC160WV
C6	C569	0244117	Ceramic	680pF $\pm 10\%$	DC50WV	Δ E7	C754	0257543	Electrolytic	3.3 μ F	DC315WV
C6	C570	0244119	Ceramic	390pF $\pm 10\%$	DC50WV	D6	C755	0244501	Ceramic	1.000pF $\pm 10\%$	DC500WV
B6	C571	0244101	Ceramic	1.000pF $\pm 10\%$	DC50WV	D6	C756	0244109	Ceramic	0.0047 μ F	DC50WV
B6	C572	0244101	Ceramic	1.000pF $\pm 10\%$	DC50WV	E7	C757	0243504	Ceramic	180pF	DC500WV
B6	C573	0252525	Electrolytic	47 μ F	DC16WV	C8	C850	0243425	Ceramic	100pF $\pm 10\%$	DC1.6kWV
B5	C575	0244171	Ceramic	0.01 μ F $\pm 5\%$	DC50WV	D7	C758	0243839	Ceramic	180pF $\pm 10\%$	DC2.5kWV
B5	C576	0252523	Electrolytic	33 μ F	DC16WV	D7	C759	0243839	Ceramic	180pF $\pm 10\%$	DC2.5kWV
E3	C601	0277023	Polyester	0.068 μ F $\pm 10\%$	DC50WV	B7	C851	0248724	Ceramic	100pF $\pm 10\%$	DC50WV
E3	C602	0251087	Electrolytic	1 μ F	DC25WV	C8	C852	0247804	Ceramic	4pF ± 0.25 pF	DC500WV
Δ E3	C603	0292708	Tantal	10 μ F $\pm 10\%$	DC16WV	C7	C853	0244136	Ceramic	270pF	DC50WV
E3	C604	0252536	Electrolytic	1.000 μ F	DC16WV	Δ A2	C900	0214479	Paper	0.068 μ F	DC450WV
E4	C605	0252565	Electrolytic	470 μ F	DC16WV	Δ A2	C901	0214480	Paper	0.1 μ F	DC450WV
E4	C606	0252821	Electrolytic	10 μ F	DC50WV	Δ A1	C902	0219425	Polyester	0.1 μ F $\pm 20\%$	DC630WV
E5	C607	0252861	Electrolytic	100 μ F	DC50WV	Δ A2	C903	0299920	Polypropylene	0.033 μ F $\pm 10\%$	DC200WV
E4	C608	0275815	Polyester	0.0047pF $\pm 10\%$	DC100WV	E1	C905	0249115	Ceramic	4.700pF $\pm 10\%$	DC500WV
E5	C609	0275817	Polyester	0.01 μ F $\pm 10\%$	DC100WV	E1	C906	0249115	Ceramic	4.700pF $\pm 10\%$	DC500WV
D5	C610	0258585	Electrolytic	22 μ F	DC160WV	E1	C907	0249115	Ceramic	4.700pF $\pm 10\%$	DC500WV
E3	C611	0279859	Polyester	0.1 μ F $\pm 10\%$	DC100WV	E1	C908	0249115	Ceramic	4.700pF $\pm 10\%$	DC500WV
D6	C641	0252821	Electrolytic	10 μ F	DC50WV	Δ E1	C909	0259843	Electrolytic	220 μ F	DC400WV
D2	C701	0277013	Polyester	0.01 μ F $\pm 10\%$	DC50WV	Δ D1	C910	0258592	Electrolytic	4.7 μ F	DC400WV
D3	C702	0277013	Polyester	0.01 μ F $\pm 10\%$	DC50WV	D1	C911	0277001	Polyester	1.000pF $\pm 10\%$	DC50WV
D3	C703	0277013	Polyester	0.01 μ F $\pm 10\%$	DC50WV	D1	C912	0277001	Polyester	1.000pF $\pm 10\%$	DC50WV
D3	C704	0277017	Polyester	0.022 μ F $\pm 10\%$	DC50WV	D1	C913	0277021	Polyester	0.047 μ F $\pm 10\%$	DC50WV
D3	C705	0243504	Ceramic	180pF	DC500WV	E1	C914	0252613	Electrolytic	3.3 μ F	DC25WV
D3	C706	0277017	Polyester	0.022 μ F $\pm 10\%$	DC50WV	E1	C915	0277019	Polyester	0.033 μ F $\pm 10\%$	DC50WV
D4	C707	0252621	Electrolytic	10 μ F	DC25WV	C1	C916	0252613	Polyester	3.3 μ F	DC25WV
D3	C708	0252613	Electrolytic	3.3 μ F	DC25WV	D1	C917	0277011	Polyester	6.800pF $\pm 10\%$	DC50WV
Δ D4	C709	0299963	Polypropylene	0.01 μ F $\pm 5\%$	DC630WV	C1	C919	0251101	Electrolytic	3.3 μ F	DC25WV
Δ D4	C710	0299961	Polypropylene	0.1 μ F	DC200WV	D1	C920	0277021	Polyester	0.047 μ F $\pm 10\%$	DC50WV
D4	C711	0277005	Polyester	0.0022 μ F $\pm 10\%$	DC50WV	D2	C921	0243507	Ceramic	330pF $\pm 10\%$	DC500WV
D4	C712	0277003	Polyester	0.0015 μ F $\pm 10\%$	DC50WV	C1	C922	0299912	Polyester	6.800pF $\pm 10\%$	DC200WV
D6	C713	0277017	Polyester	0.022 μ F $\pm 10\%$	DC50WV	C2	C925	0259844	Electrolytic	220 μ F	DC160WV
D6	C714	2048684	Ceramic	100pF $\pm 5\%$	DC50WV	Δ C2	C930	0243837	Ceramic	330pF $\pm 10\%$	DC2.5kWV
Δ D6	C715	0243512	Ceramic	820pF $\pm 10\%$	DC500WV	C2	C931	0243837	Ceramic	330pF $\pm 10\%$	DC2.5kWV
Δ D6	C716	0243505	Ceramic	220pF $\pm 10\%$	DC500WV	Δ D1	C932	0252331	Electrolytic	100 μ F	DC10WV
D6	C717	0299918	Polypropylene	0.022 μ F $\pm 5\%$	DC200WV	Δ C2	C933	0243837	Ceramic	330pF $\pm 10\%$	DC2.5kWV
Δ D7	C718	0299631	Polypropylene	0.027 μ F $\pm 10\%$	DC200WV	RESISTORS					
Δ D7	C719	0299630	Polypropylene	0.022 μ F $\pm 10\%$	DC630WV	A2	R002	0114133	Carbon film	120 Ω	SRD $\frac{1}{4}$ P
Δ D7	C720	0299633	Polypropylene	0.039 μ F $\pm 10\%$	DC200WV	A2	R003	0114175	Carbon film	3.9K Ω	SRD $\frac{1}{4}$ P
Δ D7	C721	0299922	Polypropylene	0.047 μ F $\pm 10\%$	DC200WV	A2	R004	0114203	Carbon film	12K Ω	SRD $\frac{1}{4}$ P
Δ E7	C722	0299631	Polypropylene	0.027 μ F $\pm 10\%$	DC200WV	A2	R005	0114175	Carbon film	3.9K Ω	SRD $\frac{1}{4}$ P
Δ E6	C724	0299607	Polypropylene	0.22 μ F $\pm 10\%$	DC400WV	A1	R089	0179533	Composition	1.5M Ω $\pm 5\%$	$\frac{1}{4}$ PCL
E6	C725	0299607	Polypropylene	0.22 μ F $\pm 10\%$	DC400WV	A1	R090	0114131	Carbon film	100 Ω $\pm 5\%$	SRD $\frac{1}{4}$ P
D7	C729	0277029	Polyester	0.22 μ F $\pm 10\%$	DC100WV	A1	R094	0151257	Control	50K Ω -B	RV-10
D7	C730	0243839	Ceramic	180pF $\pm 10\%$	DC2.5kWV	A1	R095	0179532	Composition	470K Ω $\pm 5\%$	$\frac{1}{4}$ PCL
D7	C731	0215246	Paper	0.068 μ F $\pm 20\%$	DC1kWV	A1	R096	0114221	Carbon film	68K Ω $\pm 5\%$	SRD $\frac{1}{4}$ P
D7	C727	0243839	Ceramic	180pF $\pm 10\%$	DC2.5kWV	A1	R097	0134218	Composition	4.7M Ω $\pm 5\%$	RC $\frac{1}{2}$ GF
E8	C732	0243504	Ceramic	180pF $\pm 10\%$	DC500WV	A1	R098	0114205	Carbon film	15K Ω $\pm 5\%$	SRD $\frac{1}{4}$ P
E7	C733	0252822	Electrolytic	22 μ F	DC50WV	A1	R099	0114209	Carbon film	22K Ω $\pm 5\%$	SRD $\frac{1}{4}$ P
E7	C735	0252536	Electrolytic	1.000 μ F	DC16WV	A1	R201	0114062	Carbon film	75 Ω	SRD $\frac{1}{4}$ P
E6	C736	0252537	Electrolytic	2200 μ F	DC16WV	B1	R202	0114049	Carbon film	22 Ω	SRD $\frac{1}{4}$ P
Δ E7	C737	0257543	Electrolytic	3.3 μ F	DC315WV	B2	R203	0114012	Carbon film	6.2 Ω	SRD $\frac{1}{4}$ P
Δ D6	C738	0258589	Electrolytic	100 μ F	DC160WV	B1	R205	0114149	Carbon film	560 Ω	SRD $\frac{1}{4}$ P
Δ E6	C739	0279859	Polyester	0.1 μ F $\pm 10\%$	DC100WV						
D6	C740	0243425	Ceramic	100pF	DC500WV						
E6	C741	0251101	Electrolytic	3.3 μ F	DC25WV						

PLACE	SYM-BOL NO.	STOCK NO.	DESCRIPTION			PLACE	SYM-BOL NO.	STOCK NO.	DESCRIPTION		
B2	R206	0114138	Carbon film	200Ω	SRD½P	C3	R325	0114177	Carbon film	4.7KΩ	SRD½P
B2	R207	0114171	Carbon film	2.7KΩ	SRD½P	C5	R326	0114151	Carbon film	680Ω	SRD½P
B2	R208	0114131	Carbon film	100Ω	SRD½P	C3	R327	0151335	Control	500Ω-B	SUB. BRIGHT
B2	R209	0114149	Carbon film	560Ω	SRD½P	D3	R328	0166675	Control	500Ω-B	BRIGHT
B2	R210	0114139	Carbon film	220Ω	SRD½P	C5	R332	0114147	Carbon film	470Ω	SRD½P
B2	R211	0114171	Carbon film	2.7KΩ	SRD½P	Δ D4	R334	0110175	Carbon film	18KΩ	
B2	R212	0114131	Carbon film	100Ω	SRD½P	C4	R335	0166674	Control	200Ω-B	CONT
B3	R213	0114171	Carbon film	2.7KΩ	SRD½P	C4	R337	0114131	Carbon film	68Ω	SRD½P
B3	R214	0114151	Carbon film	680Ω	SRD½P	C4	R338	0114153	Carbon film	820Ω	SRD½P
B3	R215	0114137	Carbon film	180Ω	SRD½P	D6	R344	0119508	Fuse resistor	56Ω	RN½
A3	R216	0114057	Carbon film	47Ω	SRD½P	C4	R346	0137571	Carbon film	680Ω	SRD½P
A3	R217	0114057	Carbon film	47Ω	SRD½P	A4	R401	0114201	Carbon film	10KΩ	SRD½P
A3	R218	0114161	Carbon film	1KΩ	SRD½P	A4	R402	0134169	Composition	220KΩ	RC½GF
B2	R219	0114147	Carbon film	470Ω	SRD½P	A5	R403	0114161	Carbon film	1KΩ	SRD½P
A4	R220	0114141	Carbon film	270Ω	SRD½P	A5	R404	0110117	Metal oxide	68Ω	RD1PB
A4	R221	0114176	Carbon film	4.3KΩ	SRD½P	A5	R408	0114297	Carbon film	470KΩ	SRD½P
A4	R222	0114183	Carbon film	8.2KΩ	SRD½P	A6	R412	0114221	Carbon film	68KΩ	SRD½P
A4	R223	0114161	Carbon film	1KΩ	SRD½P	A5	R413	0114171	Carbon film	2.7KΩ	SRD½P
A4	R224	0114207	Carbon film	18KΩ	SRD½P	A6	R414	0137659	Carbon film	22KΩ	SRD½P
B3	R225	0114063	Carbon film	82Ω	SRD½SD	A5	R415	0114143	Carbon film	330Ω	SRD½P
B2	R226	0137507	Carbon film	3.9Ω	SRD½SD	A5	R417	0114169	Carbon film	2.2KΩ	SRD½P
B3	R251	0114217	Carbon film	47KΩ	SRD½P	A6	R419	0114161	Carbon film	1KΩ	SRD½P
B2	R252	0114209	Carbon film	22KΩ	SRD½P	A6	R420	0114221	Carbon film	68KΩ	SRD½P
B2	R253	0114169	Carbon film	2.2KΩ	SRD½P	A6	R421	0110169	Metal oxide	10KΩ	RD1PB
B2	R254	0114203	Carbon film	12KΩ	SRD½P	A6	R422	0110121	Metal oxide	100Ω	
C2	R255	0114133	Carbon film	120Ω	SRD½P	A7	R452	0116673	Control	10KΩ-A	VOLUME
B2	R256	0114137	Carbon film	180Ω	SRD½P	B3	R501	0114153	Carbon film	820Ω	SRD½P
C3	R257	0114205	Carbon film	15KΩ	SRD½P	B3	R508	0114297	Carbon film	470KΩ	SRD½P
C3	R258	0114179	Carbon film	5.6KΩ	SRD½P	B3	R509	0114175	Carbon film	3.9KΩ	SRD½P
B2	R259	0114137	Carbon film	180Ω	SRD½P	C4	R510	0114183	Carbon film	8.2KΩ	SRD½P
B2	R260	0114153	Carbon film	820Ω	SRD½P	C4	R511	0114151	Carbon film	680Ω	SRD½P
C2	R261	0114175	Carbon film	3.9KΩ	SRD½P	C4	R512	0114139	Carbon film	220Ω	SRD½P
C2	R262	0114161	Carbon film	1KΩ	SRD½P	C4	R513	0114147	Carbon film	470Ω	SRD½P
B1	R263	0114179	Carbon film	5.6KΩ	SRD½P	C4	R514	0137567	Carbon film	470Ω	SRD½P
B1	R264	0114177	Carbon film	4.7KΩ	SRD½P	C4	R515	0114169	Carbon film	2.2KΩ	SRD½P
B1	R265	0151187	Control	5KΩ-A	A. G. C	B4	R518	0114213	Carbon film	33KΩ	SRD½P
B1	R266	0115167	Carbon film	1.8KΩ	SRD½P	B4	R519	0114211	Carbon film	27KΩ	SRD½P
B1	R267	0114153	Carbon film	820Ω	SRD½P	C3	R520	0014179	Carbon film	5.6KΩ	SRD½P
D3	R274	0114145	Carbon film	390Ω	SRD½P	C3	R521	0114211	Carbon film	27KΩ	SRD½P
B2	R275	0114149	Carbon film	560Ω	SRD½P	C4	R524	0114211	Carbon film	27KΩ	SRD½P
B1	R276	0114237	Carbon film	180Ω	SRD½P	C4	R525	0151296	Control	5KΩ-B	PHASE CENT.
B1	R277	0114169	Carbon film	2.2KΩ	SRD½P	C4	R526	0114211	Carbon film	27KΩ	SRD½P
B1	R280	0114177	Carbon film	4.7KΩ	SRD½P	C4	R529	0114169	Carbon film	2.2KΩ	SRD½P
B1	R282	0114211	Carbon film	27KΩ	SRD½P	C7	R531	0114171	Carbon film	2.7KΩ	SRD½P
A4	R301	0114201	Carbon film	10KΩ	SRD½P	C7	R533	0114171	Carbon film	2.7KΩ	SRD½P
C3	R302	0114145	Carbon film	390Ω	SRD½P	B7	R535	0114171	Carbon film	2.7KΩ	SRD½P
C4	R305	0114143	Carbon film	330Ω	SRD½P	C3	R543	0114149	Carbon film	560Ω	SRD½P
C4	R306	0114141	Carbon film	270Ω	SRD½P	C3	R544	0151185	Control	1KΩ-B	PHASE
C4	R308	0114133	Carbon film	120Ω	SRD½P	C3	R545	0166676	Control	2KΩ-B	COLOUR
D4	R311	0134169	Composition	220KΩ	RC½GF	C7	R548	0114141	Carbon film	270Ω	SRD½P
C5	R312	0114139	Carbon film	220Ω	SRD½P	C7	R549	0114141	Carbon film	270Ω	SRD½P
D5	R313	0114167	Carbon film	1.8KΩ	SRD½P	B7	R550	0114141	Carbon film	270Ω	SRD½P
D6	R314	0114169	Carbon film	2.2KΩ	SRD½P	B5	R555	0114149	Carbon film	560Ω	SRD½P
D4	R315	0114221	Carbon film	68KΩ	SRD½P	B5	R556	0114145	Carbon film	390Ω	SRD½P
C6	R317	0114161	Carbon film	1KΩ	SRD½P	B5	R557	0114145	Carbon film	390Ω	SRD½P
C6	R319	0114165	Carbon film	1.5KΩ	SRD½P	B5	R558	0114145	Carbon film	390Ω	SRD½P
C4	R321	0114175	Carbon film	3.9KΩ	SRD½P	B5	R559	0114151	Carbon film	680Ω	SRD½P
D3	R322	0114217	Carbon film	47KΩ	SRD½P	B6	R560	0114149	Carbon film	560Ω	SRD½P
C3	R323	0114293	Carbon film	330KΩ	SRD½P	B6	R561	0114141	Carbon film	270Ω	SRD½P
C3	R324	0114149	Carbon film	560Ω	SRD½P	B5	R562	0114151	Carbon film	680Ω	SRD½P
						B5	R563	0114169	Carbon film	2.2KΩ	SRD½P
						B5	R564	0151186	Control	500Ω-B	GAIN BALANCE

PRODUCT SAFETY NOTE — Components marked with a Δ have special characteristics important to safety. Before replacing any of these components, read carefully, the PRODUCT SAFETY NOTICE of this Service Manual. Don't degrade the safety of the receiver through improper servicing.

PLACE	SYM-BOL NO.	STOCK NO.	DESCRIPTION			PLACE	SYM-BOL NO.	STOCK NO.	DESCRIPTION		
B6	R565	0114161	Carbon film	1K Ω	SRD $\frac{1}{4}$ P	D3	R709	0114183	Carbon film	8.2K Ω	SRD $\frac{1}{4}$ P
B5	R566	0114135	Carbon film	150 Ω	SRD $\frac{1}{4}$ P	D3	R711	0114151	Carbon film	680 Ω	SRD $\frac{1}{4}$ P
B6	R567	0114201	Carbon film	10K Ω	SRD $\frac{1}{4}$ P	Δ E4	R713	0151345	Control	20K Ω -B	SUB H.HOLD
B5	R568	0114135	Carbon film	150 Ω	SRD $\frac{1}{4}$ P	D4	R714	0114205	Carbon film	15K Ω	SRD $\frac{1}{4}$ P
C6	R569	0114149	Carbon film	560 Ω	SRD $\frac{1}{4}$ P	D4	R715	0114179	Carbon film	5.6K Ω	SRD $\frac{1}{4}$ P
C6	R570	0114169	Carbon film	2.2K Ω	SRD $\frac{1}{4}$ P	Δ D4	R716	0114217	Carbon film	47K Ω	SRD $\frac{1}{4}$ P
C5	R571	0114213	Carbon film	33K Ω	SRD $\frac{1}{4}$ P	Δ D4	R717	0114053	Carbon film	33 Ω	SRD $\frac{1}{4}$ P
C5	R572	0114213	Carbon film	33K Ω	SRD $\frac{1}{4}$ P	D4	R718	0134103	Composition	8.2K Ω	RC $\frac{1}{2}$ GF
C5	R573	0114213	Carbon film	33K Ω	SRD $\frac{1}{4}$ P	E4	R719	0114147	Carbon film	470 Ω	SRD $\frac{1}{4}$ P
C5	R574	0114143	Carbon film	330 Ω	SRD $\frac{1}{4}$ P	E4	R720	0114151	Carbon film	680 Ω	SRD $\frac{1}{4}$ P
C5	R575	0114163	Carbon film	1.2K Ω	SRD $\frac{1}{4}$ P	Δ D4	R721	0110166	Metal oxide	7.5K Ω	RD1PB
B5	R576	0114213	Carbon film	33K Ω	SRD $\frac{1}{4}$ P	E6	R722	0114205	Carbon film	15K Ω	SRD $\frac{1}{4}$ P
C5	R577	0114175	Carbon film	3.9K Ω	SRD $\frac{1}{4}$ P	D6	R723	0114165	Carbon film	1.5K Ω	SRD $\frac{1}{4}$ P
C6	R578	0114175	Carbon film	3.9K Ω	SRD $\frac{1}{4}$ P	Δ D6	R724	0134093	Composition	3.3K Ω	RC $\frac{1}{2}$ GF
B5	R579	0114177	Carbon film	4.7K Ω	SRD $\frac{1}{4}$ P	Δ D6	R725	0110259	Metal oxide	3.9K Ω	RD2PB
C7	R580	0114177	Carbon film	4.7K Ω	SRD $\frac{1}{4}$ P	Δ E7	R726	0142265	Wire wound	20 Ω	RWH-10
B6	R581	0114135	Carbon film	150 Ω	SRD $\frac{1}{4}$ P	Δ D7	R727	0110151	Metal oxide	1.8K Ω	RD1PB
B6	R582	0114175	Carbon film	3.9K Ω	SRD $\frac{1}{4}$ P	Δ E7	R728	0110129	Metal oxide	220 Ω	RD1PB
B6	R583	0114175	Carbon film	3.9K Ω	SRD $\frac{1}{4}$ P	Δ E7	R733	0119502	Fuse resistor	1 Ω	RN $\frac{1}{4}$
B7	R584	0114153	Carbon film	820 Ω	SRD $\frac{1}{4}$ P	Δ E7	R734	0119505	Fuse resistor	2.2 Ω	RN $\frac{1}{4}$
B7	R585	0114153	Carbon film	820 Ω	SRD $\frac{1}{4}$ P	Δ E6	R735	0114283	Carbon film	120K Ω	SRD $\frac{1}{4}$ P
C6	R586	0114169	Carbon film	2.2K Ω	SRD $\frac{1}{4}$ P	Δ D7	R737	0190175	Wire wound	2.2 Ω \pm 10%	RD1PB
B6	R587	0114149	Carbon film	560 Ω	SRD $\frac{1}{4}$ P	E7	R741	0114011	Carbon film	5.6 Ω	SRD $\frac{1}{4}$ P
B5	R588	0114181	Carbon film	6.8K Ω	SRD $\frac{1}{4}$ P	Δ D6	R745	0110171	Metal oxide	12K Ω	RD1PB
B5	R589	0114177	Carbon film	4.7K Ω	SRD $\frac{1}{4}$ P	Δ D6	R746	0119504	Metal film	0.5 Ω	RN $\frac{1}{4}$
B5	R590	0114135	Carbon film	150 Ω	SRD $\frac{1}{4}$ P	E6	R750	0151296	Control	5K Ω -B	
E3	R601	0137621	Carbon film	6.8K Ω	RC $\frac{1}{4}$ GF	E6	R751	0114175	Carbon film	3.9K Ω	SRD $\frac{1}{4}$ P
E3	R602	0114201	Carbon film	10K Ω	SRD $\frac{1}{4}$ P	E6	R752	0114181	Carbon film	6.8K Ω	SRD $\frac{1}{4}$ P
E3	R603	0114171	Carbon film	2.7K Ω	SRD $\frac{1}{4}$ P	E6	R753	0112405	Composition	15 Ω	SRD $\frac{1}{4}$ P
E3	R604	0137623	Carbon film	8.2K Ω	RC $\frac{1}{4}$ GF	E6	R754	0134366	Compound	270 Ω	RG $\frac{1}{4}$ GF
E3	R605	0151331	Control	20K Ω -B	V.HOLD	Δ D4	R758	0110169	Metal oxide	7.5K Ω	RD1PB
Δ E3	R606	0114201	Carbon film	10K Ω	SRD $\frac{1}{4}$ P	Δ D2	R761	0119505	Fuse resistor	2.2 Ω	RN $\frac{1}{4}$
E4	R607	0151338	Control	5K Ω -B	V.SIZE	C7	R851	0114139	Carbon film	220 Ω	SRD $\frac{1}{4}$ P
E4	R608	0114201	Carbon film	10K Ω	SRD $\frac{1}{4}$ P	C7	R852	0114165	Carbon film	1.5K Ω	SRD $\frac{1}{4}$ P
E4	R609	0151329	Control	50K Ω -B	V.LIN.	C7	R853	0151338	Control	5K Ω -B	
E4	R610	0114177	Carbon film	4.7K Ω	SRD $\frac{1}{4}$ P	B7	R854	0110271	Metal oxide	12K Ω	RD2PB
E4	R611	0114217	Carbon film	47K Ω	SRD $\frac{1}{4}$ P	C7	R856	0114135	Carbon film	150 Ω	SRD $\frac{1}{4}$ P
Δ E4	R612	0114007	Carbon film	3.9 Ω	SRD $\frac{1}{4}$ P	C7	R857	0151335	Control	200 Ω -B	
E4	R613	0114182	Carbon film	7.5K Ω	SRD $\frac{1}{4}$ P	C8	R858	0114165	Carbon film	1.5K Ω	SRD $\frac{1}{4}$ P
E4	R614	0114139	Carbon film	270 Ω	SRD $\frac{1}{4}$ P	C8	R859	0151338	Control	5K Ω -B	
E4	R615	0114055	Carbon film	39 Ω	SRD $\frac{1}{4}$ P	C8	R860	0110271	Metal oxide	12K Ω	RD2PB
Δ D4	R616	0114173	Carbon film	3.3K Ω	SRD $\frac{1}{4}$ P	B7	R861	0114131	Carbon film	100 Ω	SRD $\frac{1}{4}$ P
Δ E4	R617	0114173	Carbon film	3.3K Ω	SRD $\frac{1}{4}$ P	B7	R862	0114133	Carbon film	120 Ω	SRD $\frac{1}{4}$ P
Δ E5	R618	0110157	Metal oxide	3.3K Ω	RD1PB	B7	R863	0151335	Control	200 Ω -B	
E5	R619	0114171	Carbon film	2.7K Ω	SRD $\frac{1}{4}$ P	B7	R864	0114165	Carbon film	1.5K Ω	SRD $\frac{1}{4}$ P
D5	R620	0114059	Carbon film	56 Ω	SRD $\frac{1}{4}$ P	B7	R865	0151338	Control	5K Ω -B	
Δ E3	R621	0110141	Metal oxide	680 Ω	RD1PB	B8	R866	0112071	Metal oxide	12K Ω	RD2PB
Δ E3	R622	0162625	Control	500 Ω -B	V.CENT	B7	R867	0134099	Composition	5.6K Ω	RC $\frac{1}{4}$ GF
Δ E3	R623	0119508	Fuse resistor	56 Ω	RN $\frac{1}{4}$	B8	R868	0134091	Composition	2.7K Ω	RC $\frac{1}{4}$ GF
Δ D5	R624	0110346	Metal oxide	1.1K Ω	RD3PB	C8	R869	0134091	Composition	2.7K Ω	RC $\frac{1}{4}$ GF
Δ D5	R625	0110346	Metal oxide	1.1K Ω	RD3PB	B8	R870	0134091	Composition	2.7K Ω	RC $\frac{1}{4}$ GF
D6	R641	0114181	Carbon film	6.8K Ω	SRD $\frac{1}{4}$ P	C8	R871	0134177	Composition	470K Ω	RC $\frac{1}{4}$ GF
D6	R642	0114151	Carbon film	680 Ω	SRD $\frac{1}{4}$ P	Δ C8	R872	0151635	Control	1M Ω -B	SCREEN
D2	R701	0114205	Carbon film	15K Ω	SRD $\frac{1}{4}$ P	Δ C8	R873	0134179	Composition	560K Ω	RC $\frac{1}{4}$ GF
D2	R702	0114165	Carbon film	1.5K Ω	SRD $\frac{1}{4}$ P	Δ C8	R874	0134179	Composition	560K Ω	RC $\frac{1}{4}$ GF
D3	R703	0114147	Carbon film	470 Ω	SRD $\frac{1}{4}$ P	B8	R875	0134171	Composition	270K Ω	RC $\frac{1}{4}$ GF
D2	R704	0114147	Carbon film	470 Ω	SRD $\frac{1}{4}$ P	B8	R876	0134163	Composition	120K Ω	RC $\frac{1}{4}$ GF
D3	R706	0114203	Carbon film	12K Ω	SRD $\frac{1}{4}$ P	B7	R881	0114059	Carbon film	56 Ω	SRD $\frac{1}{4}$ P
D3	R707	0114203	Carbon film	12K Ω	SRD $\frac{1}{4}$ P	C7	R882	0114059	Carbon film	56 Ω	SRD $\frac{1}{4}$ P
D3	R708	0114177	Carbon film	4.7K Ω	SRD $\frac{1}{4}$ P	B7	R883	0114059	Carbon film	56 Ω	SRD $\frac{1}{4}$ P
						Δ E1	R901	0142262	Wire wound	10 Ω	RD10PB

PRODUCT SAFETY NOTE – Components marked with a Δ have special characteristics important to safety. Before replacing any of these components, read carefully, the PRODUCT SAFETY NOTICE of this Service Manual. Don't degrade the safety of the receiver through improper servicing.

PLACE	SYM-BOL NO.	STOCK NO.	DESCRIPTION			PLACE	SYM-BOL NO.	STOCK NO.	DESCRIPTION	
D1	R902	0114219	Carbon film	56K Ω	SRD $\frac{1}{4}$ P	B6	CR551	2330351		IS2076
D1	R903	0114165	Carbon film	1.5K Ω	SRD $\frac{1}{4}$ P	B6	CR552	2330351		IS2076
Δ D1	R904	0114211	Carbon film	27K Ω	SRD $\frac{1}{4}$ P	B5	CR553	2330351		IS2076
D1	R905	0114221	Carbon film	68K Ω	SRD $\frac{1}{4}$ P	B6	CR554	2330351		IS2076
D1	R906	0114165	Carbon film	1.5K Ω	SRD $\frac{1}{4}$ P	B6	CR555	2330351		IS2076
D1	R907	0114219	Carbon film	56 Ω	SRD $\frac{1}{4}$ P	B6	CR556	2330351		IS2076
Δ C1	R908	0110275	Metal oxide ¹	18K Ω	RD3PB	Δ D6	CR641	2330252		VO6E
Δ C1	R909	0110277	Metal oxide	22K Ω	RD3PB	D3	CR701	0575001		IN34A
Δ E2	R910	0110163	Metal oxide	5.6K Ω	RD3PB	D3	CR702	0575001		IN34A
C1	R911	0114183	Carbon film	82K Ω	SRD $\frac{1}{4}$ P	Δ D7	CR703	2330564		V11N
D1	R912	0114173	Carbon film	3.3K Ω	SRD $\frac{1}{4}$ P	Δ E8	CR705	2330551		VO9C
C1	R913	0114165	Carbon film	1.5K Ω	SRD $\frac{1}{4}$ P	Δ E7	CR006	2330551		VO9C
D1	R914	0114173	Carbon film	180 Ω	SRD $\frac{1}{4}$ P	Δ E7	CR707	2330551		VO9C
C1	R915	0114179	Carbon film	5.6K Ω	SRD $\frac{1}{4}$ P	Δ D2	CR709	2330551		VO9C
D1	R916	0114215	Carbon film	39K Ω	SRD $\frac{1}{4}$ P	Δ E6	CR710	2330351		IS2076
C1	R918	0110365	Metal oxide	6.8K Ω	SRD $\frac{1}{4}$ P	Δ D6	CR711	2330351		IS2076
D1	R920	0114143	Carbon film	330 Ω	SRD $\frac{1}{4}$ P	Δ D2	CR712	2330251		VO6C
D1	R921	0114149	Carbon film	560 Ω	SRD $\frac{1}{4}$ P	Δ D2	CR713	2331173		HZ-11 $\text{\textcircled{C}}$
D1	R922	0114151	Carbon film	680 Ω	SRD $\frac{1}{4}$ P	Δ D6	CR714	2330191		SB-2C
Δ C1	R924	0111798	Metal oxide	4.7K Ω	SRD $\frac{1}{4}$ P	Δ E1	CR901	2331402		SA-12B
C2	R925	0114049	Carbon film	22 Ω	SRD $\frac{1}{4}$ P	Δ E1	CR902	2331402		SA-12B
Δ D2	R928	0110277	Metal oxide	22K Ω	SRD $\frac{1}{4}$ P	Δ E1	CR903	2331402		SA-12B
Δ D1	R931	0137611	Carbon film	2.7K Ω	RC $\frac{1}{4}$ GF	Δ E1	CR904	2331402		SA-12B
Δ C1	R933	0110369	Metal oxide	10K Ω	RD3PB	Δ D1	CR905	2330251		VO6C
Δ D1	R934	0114171	Carbon film	2.7K Ω	SRD $\frac{1}{4}$ P	Δ C1	CR906	2330251		VO6C
Δ C1	R935	0110273	Metal oxide	15K Ω	RD2PB	Δ C1	CR907	2330251		VO6C
C2	R936	0114049	Carbon film	22 Ω	SRD $\frac{1}{4}$ P	Δ C2	CR908	2331142		S-15H
Δ D2	R937	0137559	Carbon film	220 Ω	SRD $\frac{1}{4}$ P	Δ D1	CR913	2330351		IS2076
E2	R938	0114223	Carbon film	82K Ω	SRD $\frac{1}{4}$ P	D2	CR914	2330351		IS2076
D1	R941	0114135	Carbon film	150 Ω	SRD $\frac{1}{4}$ P					
COILS										
A2	L003	2141454	Mold							
A2	L005	2122011	Filter coil							
A3	L206	2141454	Filter coil							
A3	L207	2141772	Filter coil							
A4	L209	2122011	Filter coil							
C4	L301	2121696	Peaking coil	220KF						
C4	L302	2121694	Peaking coil	150KF						
C5	L303	2121699	Peaking coil	390KF						
C5	L305	2121702	Peaking coil	560KF						
C7	L306	2121991	Peaking coil	2.2KF						
A3	L401	2121693	Peaking coil	120KF						
A4	L402	2122011	Filter coil							
A4	L404	2121698	Peaking coil	330KF						
A5	L405	2141755	Sound Discriminating							
B3	L501	2141536	Band Pass coil							
C4	L502	2121706	Peaking coil	101KF						
C4	L503	2121701	Peaking coil	470KF						
C3	L504	2121821	Peaking coil	100KF						
C3	L505	2160831	Peaking coil							
B4	L506	2121692	Peaking coil	100KF						
B5	L551	2141753	Video Transformer							
B5	L552	2121822	Peaking coil	8.2JF						
B6	L553	2121701	Peaking coil	470KF						
C5	L554	2160445	Phase coil							
B5	L556	2121823	Peaking coil	8.2KF						
D4	L701	2120483	Filter coil							
D6	L702	2120333	Filter coil							
DIODES										
A1	CR091	2331081	Silicon	UPC-574J						
A1	CR092	0575001	Germanium	IN34A						
A1	CR093	0575001	Germanium	IN34A						
A1	CR094	2330632	Silicon	HZ-7 $\text{\textcircled{B}}$						
A1	CR095	2330351	Silicon	IS2076						
A4	CR201	0575005		IN60						
B2	CR251	0575005		IN60						
B3	CR252	2330351		IS2076						
B3	CR253	2330351		IS2076						
B1	CR254	0575001		IN34A						
B2	CR255	0575001		IN34A						
B1	CR256	0575005		IN60						
C3	CR303	2331161		HZ11 $\text{\textcircled{A}}/\text{\textcircled{B}}/\text{\textcircled{C}}$						
D6	CR306	2330351		IS2076						
D6	CR307	2330351		IS2076						
C6	CR308	2331161		HZ11 $\text{\textcircled{A}}/\text{\textcircled{B}}/\text{\textcircled{C}}$						
C6	CR312	2330351		IS2076						
C3	CR313	2330351		IS2076						
D4	CR316	2331351		IS2076/IS2473H						
A3	CR401	0575005		IN60						
A6	CR402	2330351		IS2076						
A6	CR403	2330351		IS2076						
B7	CR503	2331161		HZ11 $\text{\textcircled{A}}/\text{\textcircled{B}}/\text{\textcircled{C}}$						
B7	CR505	2331161		HZ11 $\text{\textcircled{A}}/\text{\textcircled{B}}/\text{\textcircled{C}}$						
B7	CR507	2331161		HZ11 $\text{\textcircled{A}}/\text{\textcircled{B}}/\text{\textcircled{C}}$						

PLACE	SYM-BOL NO.	STOCK NO.	DESCRIPTION	PLACE	SYM-BOL NO.	STOCK NO.	DESCRIPTION
E7	L703	2120333	Filter coil	B6	TR552	2320591	2SC458 (B)/(C)
△ E6	L704	2120484	Filter coil	B6	TR553	2320591	2SC458 (B)/(C)
△ E7	L705	2120482	Filter coil	B5	TR554	2320591	2SC458 (B)/(C)
△ E7	L707	2120811	Filter coil	C5	TR555	2321321	2SA844 (D)/(E)
B8	L851	2121708	Peaking coil	C5	TR556	2321321	2SA844 (D)/(E)
E1	L901	2122031	Filter coil	C5	TR557	2320591	2SC458 (B)/(C)
C5	DL301	2161521	Delay line	B6	TR558	2320591	2SC458 (B)/(C)
B5	DL551	2781881	Delay line	B7	TR559	2320591	2SC458 (B)/(C)
COMPLEX COMPONENTS				E3	TR601	2320591	2SC458 (B)/(C)
B1	CP201	2141785	Trap coil	E4	TR602	2320631	2SA673 (B)/(C)
B2	CP202	2141787	Trap coil	D3	TR701	2320591	2SC458 (B)/(C)
B2	CP203	2141786	Trap coil	△ D4	TR702	2321321	2SA844 (D)/(E)
B1	CP204	2141767	Input filter	△ D6	TR703	2321412	2SC1722BK
A4	CP206	2161503	Complex trap	△ D6	TR704	2321561	2SC1942
C4	CP301	2161513	Complex trap	△ E7	TR706	2320945	2SC1214 (C)/(D)
△ D2	CP901	2370142	Module HM9102	△ B7	TR851	2321221	2SC1514VC
△ D2	CP902	2370142	Module HM9102	△ C7	TR852	2321221	2SC1514VC
△ E5	M601	2370161	Module field scan module	△ B7	TR853	2321221	2SC1514VC
TRANSFORMERS				△ D1	TR901	0573481	2SC458 (C)
B2	T001	2141082	AFS tuning	△ D1	TR902	0573481	2SC458 (C)
B2	T201	2141145	IFT	△ D1	TR903	0573480	2SC458 (B)
B3	T202	2141146	IFT	△ C1	TR904	2320631	2SA673 (B)/(C)
A3	T203	2141528	IFT	△ D1	TR905	2321412	2SC1722 BK
B2	T204	2141529	IFT	△ C2	TR906	2321561	2SC1942
△ A7	T401	2250352	Sound output transformer	△ D2	TR907	0573480	2SC458 (B)
B3	T501	2141538	Band pass transformer	△ D1	TR908	0573481	2SC458 (C)
B5	T551	2141754	Video transformer	△ D1	TR909	2320631	2SA673 (B)/(C)
B6	T552	2141752	Video transformer	IC'S			
△ D4	T701	2161342	Line oscillator transformer	A2	IC001	2360511	HA1126DW
△ D6	T702	2260021	Line drive transformer	△ A5	IC401	2360392	HA1124A
△ E8	T703	2431577	Line output transformer	△ B4	IC501	2360442	HA11580A
△ E6	T704	2270185	Side pinchution transformer	MISCELLANEOUS			
△ D2	T901	2260021	Line drive transformer			3159471	Back cover
△ C2	T902	2270571	Pulse transformer			3113731	Cabinet
TRANSISTORS						2490431	HP-538 Button
B2	TR201	2321511	2SC1855			3742781	Knob-Push
B2	TR202	2321511	2SC1855			3258712	Knob-Contrast, bright, colour
B3	TR203	2320141	2SC717	△		3741247	Knob-Mains switch
B2	TR251	2320591	2SC458 (B)/(C)	△		2351131	Colour picture tube 510HWB22
C3	TR252	2320638	2SA673 (B)/(C)/(D)	△		2440706	Scan coil
B2	TR253	2321321	2SA844 (D)/(E)			2771382	C-F magnet
B2	TR254	2320591	2SC458 (B)/(C)			3739443	Presetter covering
A4	TR301	2320596	2SC458 (C)/(D)	△		2410455	Speaker
C4	TR302	2320598	2SC458 (B)/(C)/(D)	△	L905	2161496	Degaussing coil
C5	TR304	2321321	2SA844 (D)			2590782	Tuner P.W.B Assy
C6	TR305	2320635	2SA673 (C)/(D)			2509323	CPT BOARD Assy
C3	TR306	2320598	2SC458 (B)/(C)/(D)			3320683	Power supply & deflection chassis Assy
△ A6	TR401	2321433	2SD478 (C)/(D)			2509972	Filter BOARD Assy
△ A6	TR402	2321433	2SD478 (C)/(D)				
B5	TR551	2320591	2SC458 (B)/(C)				

PRODUCT SAFETY NOTE – Components marked with a Δ have special characteristics important to safety. Before replacing any of these components, read carefully, the PRODUCT SAFETY NOTICE of this Service Manual. Don't degrade the safety of the receiver through improper servicing.

PLACE	SYM-BOL NO.	STOCK NO.	DESCRIPTION
		3320696	Signal BOARD Assy
		2509301	Chroma module
		2422751	Tuner ET-536
		2685962	Socket Aerial socket
		2742115	Plug Aerial plug
Δ		2630921	Switch-Power switch
		2741744	Cord-AC cord
		2630781	Micro switch
	X501	2783073	X'tal
	CF401	2140921	Ceramic filter (6.0MHz)
		2720221	Fuse holder
Δ	F901	2720173	Fuse 2A/T
Δ	F902	2720173	Fuse 2A/T
Δ	F903	2720179	Fuse 0.8A/T
Δ	F701	2720401	Fuse 630mA/T
		4614001	Wedge
Δ	TF601	2720245	Fuse temp fuse 139° C
		9413926	Silicon gum
		2051667	Socket CPT socket
		4782841	Tape for wedge
Δ	NE851	2340181	Neon lamp
Δ	NE852	2340181	Neon lamp
Δ	NE853	2340181	Neon lamp
Δ	NE854	2340181	Neon lamp
Δ	NE855	2340181	Neon lamp
Δ	TF401	2720245	Fuse temp fuse 139° C
		2657531	Socket 10p socket
		2662291	Plug 10p plug
		2657511	Socket 24p IC socket
Δ	TH601	2340341	Thermistor 11D4H
Δ	TH901	2340401	PTC Thermistor 112301-9
	TH251	2340371	Thermistor

- Since this is a basic circuit diagram, the value of the parts is subject to be altered for improvement.
- All DC voltage to be measured with a tester (100K Ω /V). Voltages taken on a complex colour bar signal including a standard colour bar signal.
- All resistors are in ohms. K=1,000 M=1,000K
- All capacitors are in μ F, unless otherwise noted. P= μ M
-  indicates a fuse resistor.

BASIC CIRCUIT SCHEMATIC I

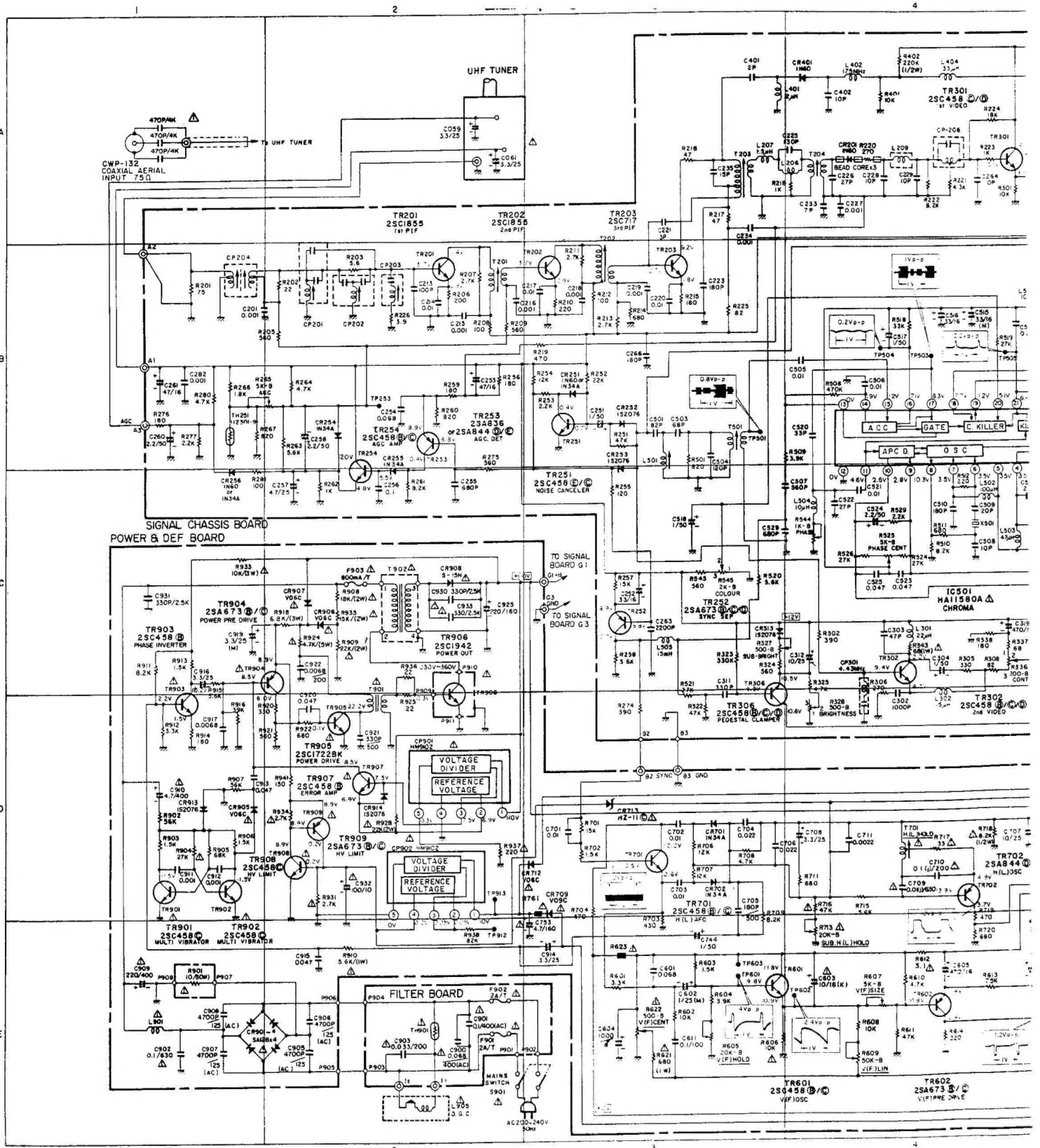



HITACHI ALL TRANSISTOR NP6C CHASS

the value of the parts
ment.

a tester (100K Ω /V).
bar signal including a standard colour bar signal.

=1,000K
se noted. P= μ mF

Components marked v
read carefully the proc

BASIC CIRCUIT SCHEMATIC DIAGRAM (CWP-132)

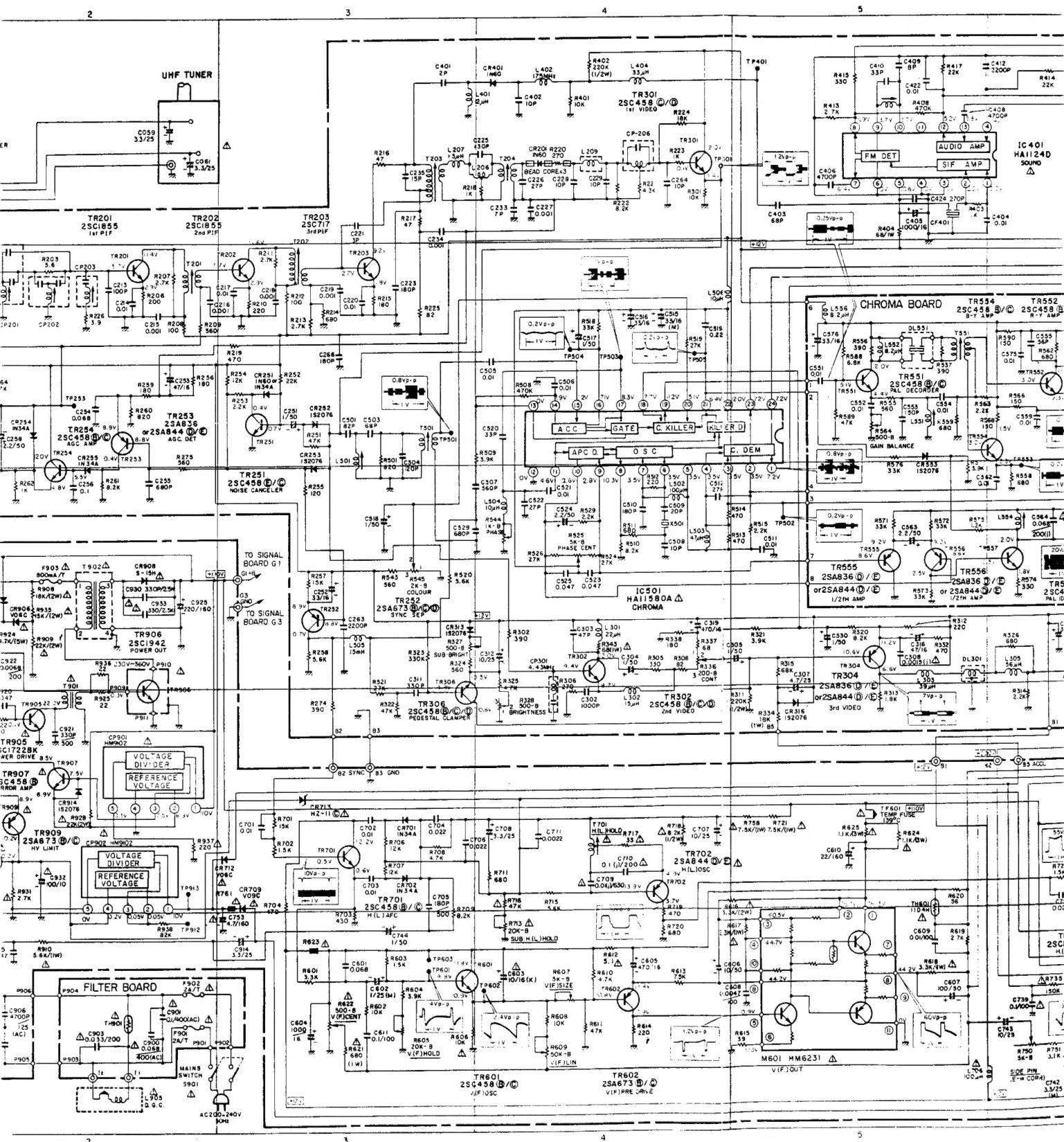

STOR NP6C CHASSIS

PRODUCT SAFETY NOTE

Components marked with a Δ and shaded have special characteristics important to safety. Before replacing any of these components read carefully the product safety notice of this service manual. Don't degrade the safety of the receiver through improper servicing.

IMPORTANT

The component shaded in red is sealed at the factory.
No attempt shall be made to adjust or defeat T701.

Refer to Page 5 in Service Manual when it is necessary to adjust the sealed component during servicing.

DIAGRAM (CWP-132)

